

**Hewlett-Packard
SureStore E Hub
Models S10 and L10**

Hewlett-Packard SureStore E Hub
Models S10 and L10
Service and User Manual



Edition E0899

Order No. A3724-90006

Printed in U.S.A.

Notice

© Hewlett-Packard Company, 1997, 1998, 1999.
All rights reserved.

Hewlett-Packard Company makes no warranty of any kind with regard to this material, including, but not limited to, the implied warranties of merchantability and fitness for a particular purpose. Hewlett-Packard shall not be liable for errors contained herein or for incidental or consequential damages in connection with the furnishing, performance, or use of this material.

This document contains proprietary information, which is protected by copyright. No part of this document may be photocopied, reproduced, or translated into another language without the prior written consent of Hewlett-Packard. The information contained in this document is subject to change without notice.

Warranty

If you have any questions about the warranty for this product, contact your dealer or local Hewlett-Packard sales representative.

Trademark Information

HyperTerminal is a registered trademark of Hilgreave, Inc.

Windows and Windows NT are either a registered trademark or trademark of Microsoft Corporation in the United States and/or other countries.

Safety Instructions

Grounding

This product is a safety class I product and has a protective earthing terminal. There must be an uninterruptible safety earth ground from the main power source to the product's input wiring terminals, power cord, or supplied power cord set. Whenever it is likely that the protection has been impaired, disconnect the power cord until the ground has been restored.

Service

Any servicing, adjustment, maintenance, or repair must be performed only by authorized service-trained personnel.

Format Conventions

Denotes

WARNING	A hazard that can cause personal injury
Caution	A hazard that can cause hardware or software damage
Note	Significant concepts or operating instructions
this font	Text to be typed verbatim: all commands, path names, file names, and directory names
this font	Text displayed on the screen
<ENTER>	Keys to be pressed, for example, the <ENTER> key

CONTENTS

1 Product Description	11
Overview	12
Features	13
Front Panel, Model S10 Short-Wave Hub	14
Front Panel, Model L10 Long-Wave Hub	15
Rear Panel, Short-Wave and Long-Wave Hubs	16
Supported Topologies	17
Single Short-Wave Hub Topology	17
Cascaded Short-Wave Hub Topology	18
Cascaded Long-Wave Hub Topology	19
2 Installation	21
Overview	22
Procedure 1: Prepare to Install the Hub	23
Procedure 2: Unpack the Hub	24
Procedure 3: Verify Hub Operation	25
Procedure 4: Mount the Hub into a Rack (Optional)	27
Procedure 5: Plan the FC-AL Connections	32
Correct Cabling Example for a Short-Wave Hub	32
Correct Cabling Example for a Long-Wave Hub	33
Incorrect Cabling Examples	35
Nonsupported Cabling Example	37
Procedure 6: Connect FC-AL Devices	38
Procedure 7: Verify the Connections	40

For HP-UX servers:	40
For HP NetServers:	40

3 RS-232 Interface Functions 41

Overview	42
About the RS-232 Main Menu	43
Tips for Using the RS-232 Interface	44
Setting Up an RS-232 Connection	45
Setting Up a Connection to a PC	45
Setting Up a Connection to a Dumb Terminal	46
Updating the Hub Firmware	48
Procedure 1: Obtain the Current Firmware	49
Procedure 2: Reboot the Hub	49
Procedure 3: Update the Hub Controller Firmware	50
Procedure 4: Update the Hub Device Agent Code	52
Procedure 5: Reset the Hub	53
Procedure 6: Set Manufacturing Values	54
Enabling Hub Management	57
Setting Hub IP Address and Network Configuration Options	57
Verifying and Setting SNMP Values	58
Configuring Cascaded Hubs	60
Running Diagnostic Tests	64
Viewing Hub Information	65

4 Troubleshooting 67

Troubleshooting Procedures	68
LED Indicators	70

If the Power LED Is Off	72
If the Hub Fault LED Stays on After Self-Test.....	73
If a Fan Is Not Operating	74
If a Device Is Unlisted/UNCLAIMED in ioscan or Not Displayed in SCSI Adapters Window	75
If a Port LED Is Off	76
If a Port LED Is On When It Should Be Off	77
If the Management Server Cannot Ping the Hub.....	78
If Firmware Upgrade Appears to Fail.....	79
Recovering from Failed Firmware Upgrade	80
5 Maintenance and Replacement.....	85
Introduction.....	86
Maintenance.....	87
Replacing the Fan Module	88
6 Reference	91
Standard Configurations	92
Configuration Options	95
Replacement Parts	97
Operating Requirements	100
Software and Operating System Requirements.....	100
Physical and Cabling Requirements	100
Supported Hardware.....	103
Supported Distances.....	104
Environmental Specifications	107
Physical Characteristics of Standalone Hub	108
Reference Documents	109

Regulatory Statements	110
Laser Safety	113

Glossary	117
-----------------------	-----

Index	121
--------------------	-----

FIGURES

1	Front Panel Display, Short-Wave Hub	14
2	Front Panel Display, Long-Wave Hub	15
3	Rear Panel	16
4	Example Topology: 10 Ports Shared among Server and FC-AL Devices	17
5	Example Topology: Cascaded Short-Wave Hubs	18
6	Example Topology: Cascaded Long-Wave Hubs	19
7	Standalone Product Contents	24
8	Replacing Mounting Ear Brackets and Nylon Retainers	27
9	Installing Rails	28
10	Installing the Hub into the Rack	29
11	Installing the Plenum Shroud	30
12	Hub Correctly Installed in a Rack	31
13	Cascaded Short-Wave Hub Configuration	33
14	Cascaded Long-Wave Hub Configuration	34
15	Incorrect Cabling Example: Connected Ports on the Same Hub	35
16	Incorrect Cabling Example: Disconnected Cable	35
17	Incorrect Cabling Example: More Than One Cable Connection Between Hubs	36
18	Incorrect Cabling Example: Long-Wave Port Connections to Wrong Device/Port	36
19	Nonsupported Cabling Example: More Than Two Hubs Connected	37
20	Nonsupported Cabling Example: HP-UX Server and HP NetServer Connected to Same Hub	37
21	Removing the Fan Module	89
22	Replacing the Fan Module	90

23	HP SureStore E Hub, Standalone	93
24	HP SureStore E Hub, Factory-Racked	94
25	Model S10 or L10 Option 001 Hub Rackmount Kit	96
26	HP SureStore E Hub Replaceable Parts	97

TABLES

1	Worksheet for Hub Configuration	42
2	LED Indications	70
3	HP SureStore E Hub Product Numbers	92
4	HP SureStoreE Hub Configuration Options	95
5	HP SureStore E Hub Replaceable Parts and Service Part Numbers	98
6	Multimode Fiber Optic Cable Part Numbers	98
7	Power Cord Part Numbers	99
8	Cable Plant Specifications: Single-Mode (2 km–10 km, 100 MB/sec)	101
9	Cable Plant Specifications: 50-Micron Multimode (500 m, 100 MB/sec) Non-OFC Operation	102
10	Cable Plant Specifications: 62.5-Micron Multimode (175 m, 100 MB/sec) Non-OFC Operation	102
11	Supported Cable Distances	104
12	Environmental Specifications for Model S10 Short-Wave and Model L10 Long-Wave Hubs	107
13	Physical Characteristics of Model S10 Short-Wave and Model L10 Long-Wave Hubs	108

1

PRODUCT DESCRIPTION

Overview

Features

Front Panel, Model S10 Short-Wave Hub

Front Panel, Model L10 Long-Wave Hub

Rear Panel, Short-Wave and Long-Wave Hubs

Supported Topologies

Overview

The Hewlett-Packard SureStore E hub, short-wave model S10 and long-wave model L10, is a full-duplex, 1063-megabit-per-second hub. It increases loop reliability, number of loop connections, and distances between server and mass storage devices in a Fibre Channel Arbitrated Loop. The hub's port detection and bypass circuitry dynamically detects and bypasses a failed node on the loop. Nodes can be added, removed, and reconnected without bringing down the loop and disrupting communication for other nodes.

Fibre Channel Manager is a web-based software application that allows you to remotely manage and monitor the health of the hub. To learn more about Fibre Channel Manager, visit the Hewlett-Packard (Software Depot (<http://www.software.hp.com>)). Fibre Channel Manager is available as a free download from this web site.

Older hubs may require a firmware upgrade to meet Fibre Channel Manager's minimum requirements. The Software Depot web site has more information about this. The latest hub firmware and upgrade instructions are available as a free download from this web site.

Detailed configuration information and part numbers for the hub are provided in chapter 6, Reference.

Features

HP SureStore E hubs provide the following features:

- **Short-wave hub (model S10):** 10 non-Open Fibre Control (non-OFC) short-wave optical transceivers
- **Long-wave hub (model L10):** nine non-OFC, short-wave optical transceivers and one non-OFC, long-wave optical transceiver
- Local retiming and regeneration of transmit signals to prevent accumulation of jitter and improve the signal
- Reliable, automatic bypass of failed nodes; dynamic recognition of newly added or removed nodes, with a controller in each port permitting the bypass of a port if the port fails signal validity tests
- Active loop reconfiguration when a node to an arbitrated loop is added, removed, or moved
- Plug-and-play capability, which allows the hub to connect to compatible servers and other Fibre Channel Arbitrated Loop (FC-AL) devices while they are operating (FC-AL devices can be added or removed while the hub is active.)
- Cascade support (hub-to-hub connections) for increased loop distances

Cascaded short-wave hubs are supported up to 500 meters; cascaded long-wave hubs are supported up to 3000 meters (3 km). Under certain conditions, cascaded long-wave hubs are supported up to 10,000 meters (10 km) (see page 105 for more information). The 10-km capability only applies to long-wave hubs connected to HP-UX servers.

Note Increased loop distances are associated with increased latency times.

- Access to the RS-232 interface for firmware upgrades and hub configuration and troubleshooting
- Support for a hub management tool (Fibre Channel Manager) to remotely manage and monitor the health of the hub

Front Panel, Model S10 Short-Wave Hub

The front panel contains LEDs for monitoring power, fault, and port status. The RS-232 port is provided to configure and troubleshoot the hub and to upgrade its firmware. The 10Base-T port provides an ethernet connection if you choose to manage the hub with Fibre Channel Manager.

The Reset button resets the internal control microprocessor of the hub. Pushing the Reset button also forces loop initialization on all devices in the loop.

Figure 1 Front Panel Display, Short-Wave Hub

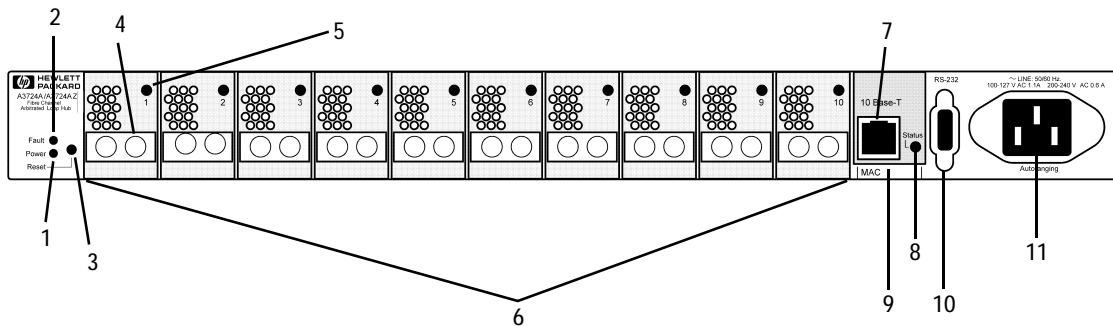

- | | |
|--|-----------------------|
| 1 Power LED | 7 10Base-T port |
| 2 Fault LED | 8 10Base-T Status LED |
| 3 Reset button | 9 MAC address |
| 4 Fibre Channel connector (Port 1 indicated) | 10 RS-232 port |
| 5 Port LED (Port 1 indicated) | 11 AC power connector |
| 6 FC-AL short-wave ports and Port LEDs | |

Front Panel, Model L10 Long-Wave Hub

The front panel contains LEDs for monitoring power, fault, and port status. The long-wave port is between port 9 and the 10Base-T port. The RS-232 port is provided to configure and troubleshoot the hub and to upgrade its firmware. The 10Base-T port provides an ethernet connection if you choose to manage the hub with Fibre Channel Manager.

The Reset button resets the internal control microprocessor of the hub. Pushing the Reset button also forces loop initialization on all devices in the loop.

Figure 2 Front Panel Display, Long-Wave Hub

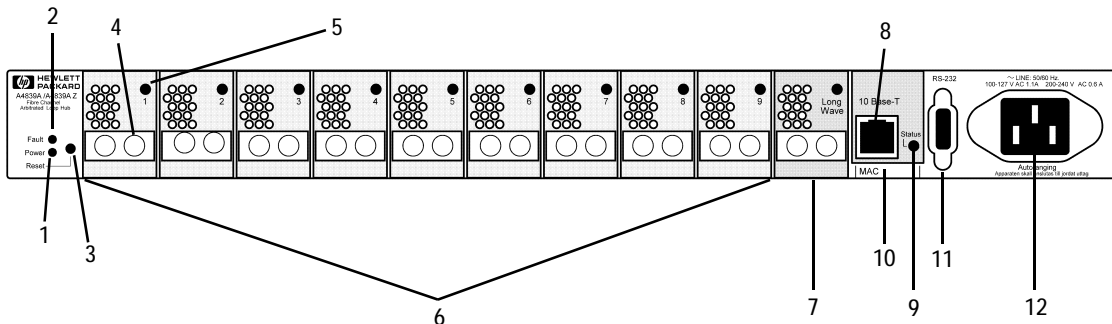

- | | |
|--|-------------------------------------|
| 1 Power LED | 7 FC-AL long-wave port and Port LED |
| 2 Fault LED | 8 10Base-T port |
| 3 Reset button | 9 10Base-T Status LED |
| 4 Fibre Channel connector (Port 1 indicated) | 10 MAC address |
| 5 Port LED (Port 1 indicated) | 11 RS-232 port |
| 6 FC-AL short-wave ports and Port LEDs | 12 AC power connector |

Rear Panel, Short-Wave and Long-Wave Hubs

Three fans, located in a customer-replaceable module at the rear panel, cool the hub. If one fan fails, the remaining two fans cool the hub temporarily, but it is important to replace the module as soon as possible (see chapter 5, Maintenance and Replacement).

Figure 3 Rear Panel

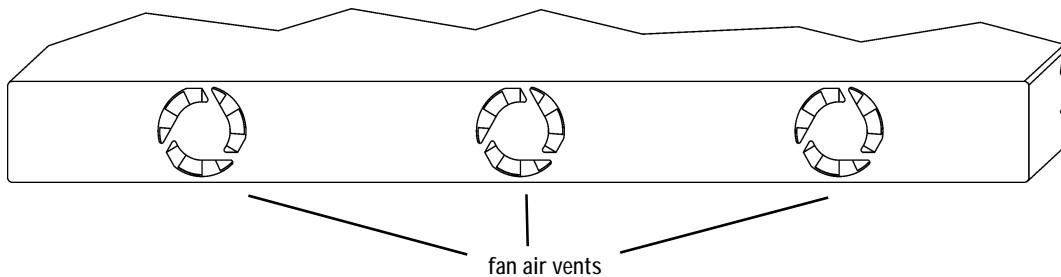

Caution Although the module will continue to run with two fans, a full complement of fans ensures system and data integrity.

Supported Topologies

Devices such as FC-AL disk arrays and HP system servers that support FC-AL can be connected to the hub in a loop that includes one or more servers. All nodes in the loop must be 1063 Mbps short-wave, non-OFC, FC-AL. The ports connected by a cable must have the same optical transceivers. Figure 4, Figure 5, and Figure 6 show typical hub topologies. For details on supported topologies, contact an HP sales representative.

Single Short-Wave Hub Topology

For the model S10 short-wave hub, Hewlett-Packard recommends 50-micron multimode fiber cable for new installations, but also supports 62.5-micron multimode fiber cable with SC-style connectors in existing installations. Stated distances assume 50-micron multimode cable.

A server with an FC-AL short-wave adapter can connect to an hub 500 meters away. Each of the 10 ports on the short-wave hub can connect to an FC-AL device up to 500 meters away. The maximum distance between the server and the end FC-AL device is 1000 meters (1 km).

Figure 4 Example Topology: 10 Ports Shared among Server and FC-AL Devices

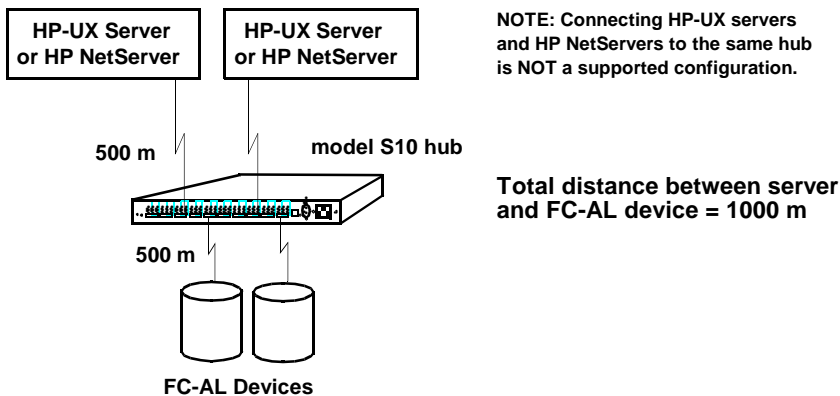

Cascaded Short-Wave Hub Topology

The example in Figure 5 shows two model S10 hubs connected in a cascade topology. Cascaded short-wave hubs use one port on each hub for the hub-to-hub connection. Such a configuration increases the potential distance between nodes in the loop an additional 500 meters. The maximum distance between the server and FC-AL devices with cascaded short-wave hubs is 1500 meters (1.5 km).

Figure 5 Example Topology: Cascaded Short-Wave Hubs

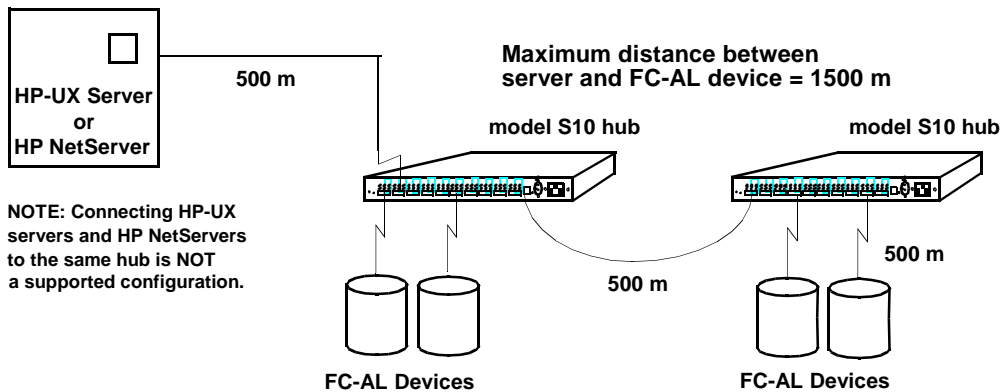

Cascaded hubs must have the same firmware versions to operate properly. If you are using Fibre Channel Manager to manage cascaded hubs, configure the hub that has the LAN (ethernet) connection as a parent hub and the remaining hub as a child hub (see Configuring Cascaded Hubs on page 60).

Cascaded Long-Wave Hub Topology

Cascaded FC-AL, non-OFC, model L10 long-wave hubs use the long-wave port for the hub-to-hub connection. The maximum supported distance between cascaded long-wave hubs with single-mode 9 micron cable is 3 km. The maximum distance between a server and FC-AL devices on cascaded long-wave hubs is, therefore, 4000 meters (500 m + 3000 m + 500 m). Under certain conditions, cascaded long-wave hubs are supported up to 10,000 meters (10 km) (see page 105 for more information). The 10-km capability only applies to long-wave hubs connected to HP-UX servers.

Caution When cascading long-wave hubs, only connect long-wave ports to long-wave ports or short-wave ports to short-wave ports.

Ports 1 through 9 on each long-wave hub are for connections to FC-AL devices. Ports 1 through 9 can also be used in a cascaded configuration; however, the maximum distance between hubs decreases from 3000 meters to 500 meters.

Figure 6 Example Topology: Cascaded Long-Wave Hubs

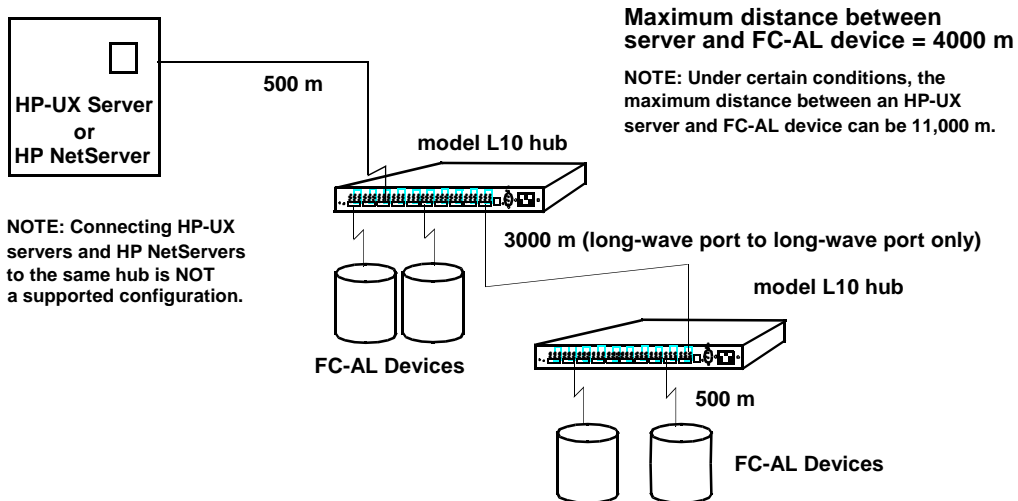

Cascaded hubs must have the same firmware versions to operate properly. If you are using Fibre Channel Manager to manage cascaded hubs, configure the hub that has the LAN (ethernet) connection as a parent hub and the remaining hub as a child hub (see page 60 for more information).

Overview

Procedure 1: Prepare to Install the Hub

Procedure 2: Unpack the Hub

Procedure 3: Verify Hub Operation

Procedure 4: Mount the Hub into a Rack (Optional)

Procedure 5: Plan the FC-AL Connections

Procedure 6: Connect FC-AL Devices

Procedure 7: Verify the Connections

Overview

The procedures for installing an HP SureStore E model S10 or model L10 hub are the following:

1. Prepare to install the hub.
2. Unpack the hub.
3. Verify hub operation.
4. Mount the hub in a rack (optional).
5. Plan the FC-AL connections.
6. Connect the FC-AL devices.
7. Verify the connections.

Read this chapter completely before installing the hub or attaching any FC-AL devices to the hub.

Procedure 1: Prepare to Install the Hub

Before installing the hub:

- Complete site-required arrangements for the hub.
- Make sure electrical power and temperature control requirements are met.
- Define a strategy for integrating the hub into an existing loop.
- Draw a map of all nodes to be connected to the hub.

Procedure 2: Unpack the Hub

1. Unpack and inspect the hub for damage that may have occurred during shipment.
2. Save the boxes and packing materials in case there is damage or anything needs to be reshipped at a future date.
3. Verify that all items shown in Figure 7 are present. Contact an HP sales representative if items are missing.
4. If the hub is to be used as a standalone unit, attach the four rubber feet to the bottom corners of the hub. Optionally, remove the hub's preinstalled mounting ear brackets and nylon retainers. The brackets and retainers are used to mount the hub in a rack.

Figure 7 Standalone Product Contents

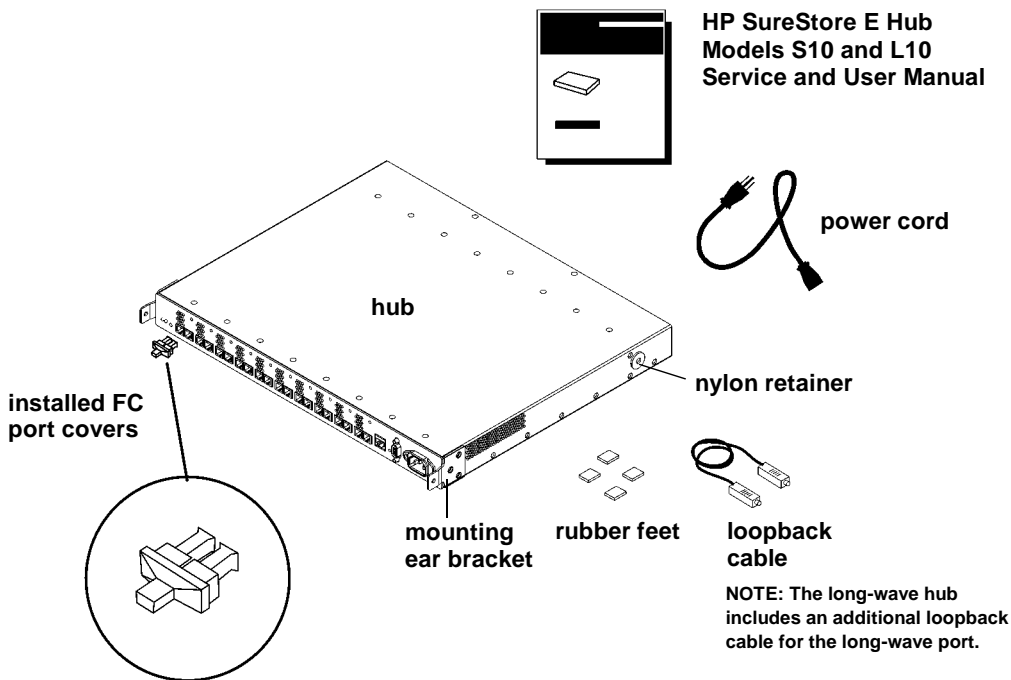

Procedure 3: Verify Hub Operation

By performing this procedure, you test the hub and verify that it operates properly before you mount it in a rack or connect any devices to it.

1. To initialize the self-test, first plug the power cord into the hub and then into a power receptacle. The hub does not have a power switch.

The hub runs the self-test each time the power cord is plugged in or the Reset button is pressed.

Note The hub's power supply automatically adjusts to a range of 100 VAC \pm 10% or 240 VAC \pm 10%.

2. The hub finishes the self-test in less than 15 seconds.

If the Fault LED (amber) stays on after self-test, the hub failed. Refer to chapter 4, Troubleshooting, or contact an HP service representative for assistance.

If the Power LED does not light, refer to chapter 4, Troubleshooting, or contact an HP service representative.

Note Interruptions to the hub's AC power source initiate a self-test. Make sure the power source circuits are properly grounded before using the supplied power cord to connect the hub to the circuit.

3. Verify that each Fibre Channel port is operating properly. Insert the loopback cable into the port and verify that the port status LED turns on. Both ends of the loopback cable plug into the port connectors.

If you plan to use Fibre Channel Manager to manage the hub, continue with step 4. If you do not plan to use Fibre Channel Manager or another hub management tool, go to step 7.

-
4. Verify that the 10Base-T port is operating properly. Insert an ethernet cable that is connected to the LAN into the 10Base-T port, and verify that the 10Base-T status LED turns on. (The status LED may begin flashing.)
 5. Set the hub IP address and configure the hub as described in chapter 3, RS-232 Interface Functions.
 6. Verify the connection between the HP-UX server and the hub. At the management server where Fibre Channel Manager is or will be installed, execute the following command:

`/etc/ping <hub IP address>` Example: `/etc/ping 15.43.214.13`

Fibre Channel Manager requires HP-UX 10.20 or 11.0 on the management server.

If you are unable to ping the hub, refer to If the Management Server Cannot Ping the Hub on page 78.

7. Unplug the hub.

Procedure 4: Mount the Hub into a Rack (Optional)

The hub mounts into any standard HP 19-inch wide EIA cabinet. The hub's front panel will face the rear of the cabinet. The front of the hub contains the 10 Fibre Channel connectors. You will need a T25 Torx head screwdriver to complete this procedure.

1. Record the serial number, located on the bottom of the hub, and the MAC address, located under the 10Base-T port. The MAC address is unique and cannot be changed.
2. Verify that the rack is adequately secured and has enough space (1 EIA) for the hub. Remove filler panels as needed from the front of the cabinet and open the rear door.
3. If the rubber feet are attached to the bottom of the hub, peel off the feet. Attach the mounting ear brackets and nylon retainers if they are missing from the left and right sides of the hub (Figure 8).

Secure the mounting ear brackets with three M3 x .5 screws to each front outside corner, turning the angled end of the bracket outward. Attach the nylon retainers with one screw through the center of the retainer and into the hole in each side of the hub.

Figure 8 Replacing Mounting Ear Brackets and Nylon Retainers

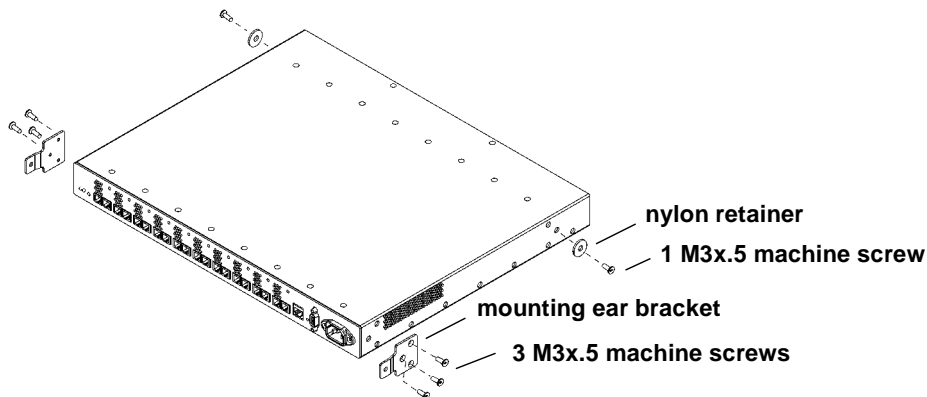

4. Slide a sheet metal nut onto the outer column in the back of the rack. Make sure to align the hole in the nut with the hole at the selected EIA location on the column.

-
5. Insert one end of the left rail in the adjoining slot. Line up the hole in the rail lines with the holes in the nut and column (Figure 9).
 6. Use a second sheet metal nut and repeat steps 4 and 5 to attach the other end of the rail to the inner column on the front of the rack.

Note DO NOT attach screws at this time.

Figure 9 Installing Rails

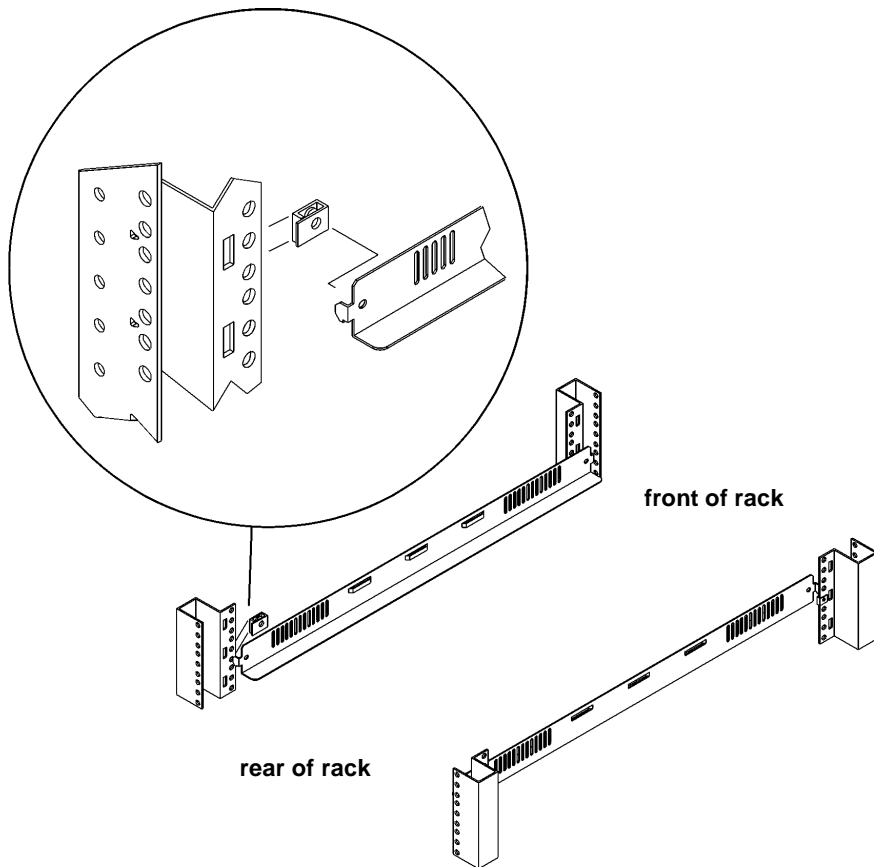

-
7. Repeat step 4 through step 6 to install the right rail.
 8. Position the hub in the rack. Align the hole in each mounting ear bracket with the holes in the assembled rail, nut, and column.
 9. Insert a 10–32 x .625 machine screw through the mounting ear bracket, rail, nut, and column on each side of the hub (Figure 10). Tighten the screws.

Figure 10 Installing the Hub into the Rack

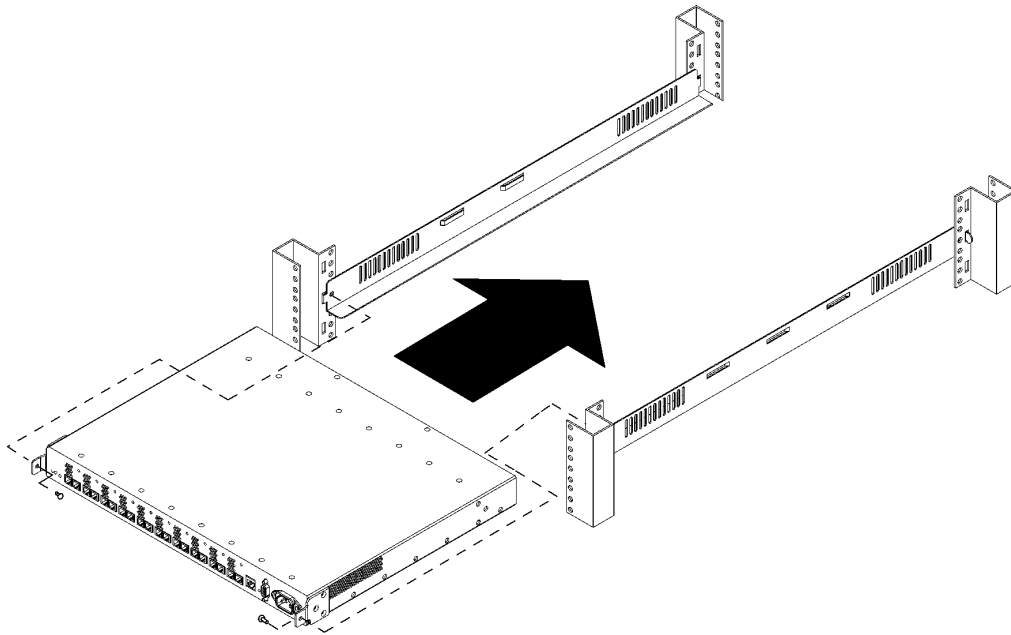

10. Slide the plenum shroud into the front side of the rack. Align the holes in the plenum shroud brackets with the holes in the assembled rails and outer posts.

11. Secure the brackets to the posts with 10–32 x .625 machine screws (Figure 11).

Figure 11 Installing the Plenum Shroud

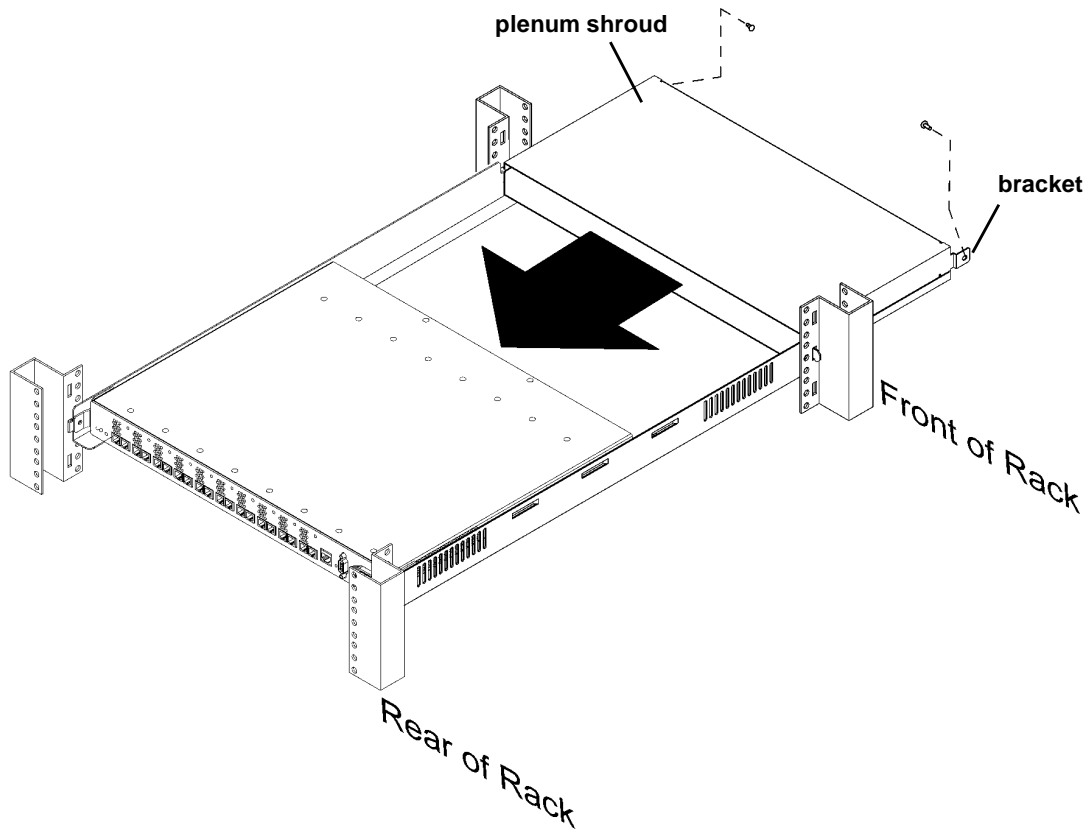
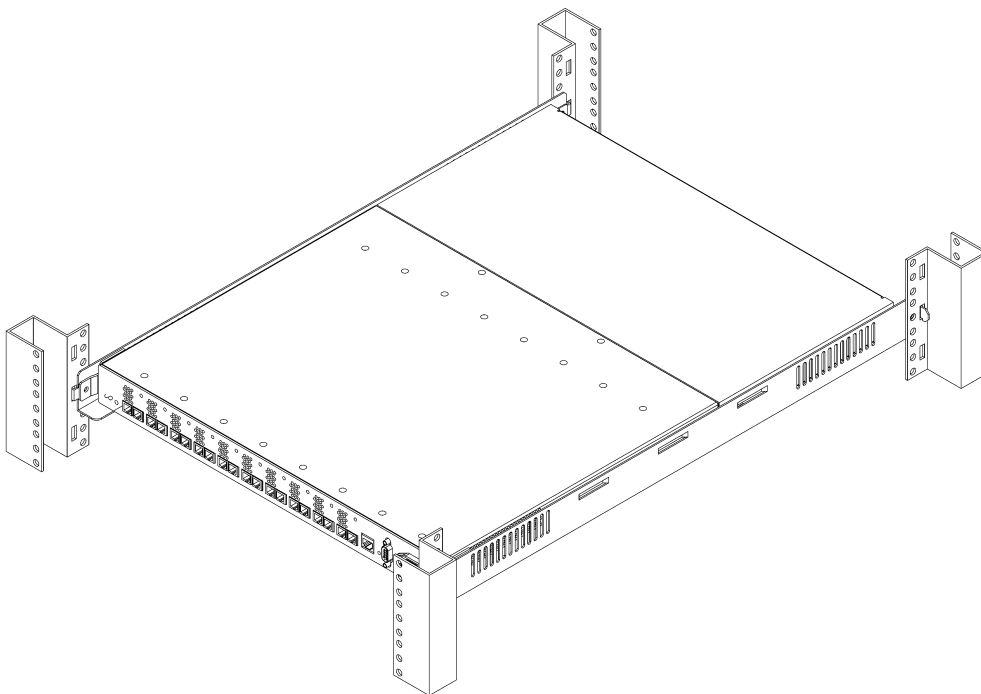

Figure 12 Hub Correctly Installed in a Rack



12. Plug the PDU cable into the cabinet PDU when you are ready to power on the hub. The hub finishes the self-test in less than 15 seconds. Verify that the hub passes the self-test.

If the Fault LED (amber) stays on after self-test, the hub failed. Refer to chapter 4, Troubleshooting, or contact an HP service representative for assistance.

If the Power LED is not lighted, refer to chapter 4, Troubleshooting, or contact an HP service representative.

13. Reinstall filler panels over the plenum shroud.

Procedure 5: Plan the FC-AL Connections

The hub does not require drivers or specific versions of operating systems. However, systems and FC-AL devices that can connect to the hub do have driver and operating system requirements. Contact an HP sales representative for information on hardware and software requirements for the systems or FC-AL devices you plan to connect to the hub. The *HP Fibre Channel Manager User Manual* lists operating system requirements for Fibre Channel Manager.

1. Verify that the loop cabling configuration is correct by comparing it to the cabling examples on the following pages. Modify the network cabling map as needed.

Caution Incorrect wiring can lead to problems such as devices left off the loop and inaccessible by the server. Follow the guidelines below before starting.

2. Refer to your cabling map to review the user-assigned loop ID (hardware address) of each FC-AL device to be connected to the hub, and verify that each ID is unique. Duplicate IDs on the loop can cause problems.
3. Verify that the connections between the hub port and the FC-AL mass storage device or the FC-AL adapter are of the same wave type and speed. For example, plan to connect a short-wave port on the hub to a short-wave port on an FC-AL device.
4. Document the planned connections in a cabling map.

Correct Cabling Example for a Short-Wave Hub

For the model S10 short-wave hub, Hewlett-Packard recommends 50-micron multimode fiber cable for new installations but also supports 62.5-micron multimode fiber cable with SC-style connectors in existing installations.

In a cascaded configuration of model S10 short-wave hubs, connect any port on the first hub to any port on the second hub. Figure 13 includes all 18 nodes in the loop formed by FC-AL Device 1, Hub A, Hub B, and FC-AL Device 2:

- Port 1 on Hub A connects to FC-AL Device 1.
- Port 10 of Hub A connects to Port 1 of Hub B.
- Port 10 on Hub B connects to FC-AL Device 2.

In this configuration, any unused port on Hub A or Hub B can connect to any compatible FC-AL device. This is just one example of cascaded short-wave hubs. The connection between short-wave hubs can occupy any combination of ports.

Figure 13 Cascaded Short-Wave Hub Configuration

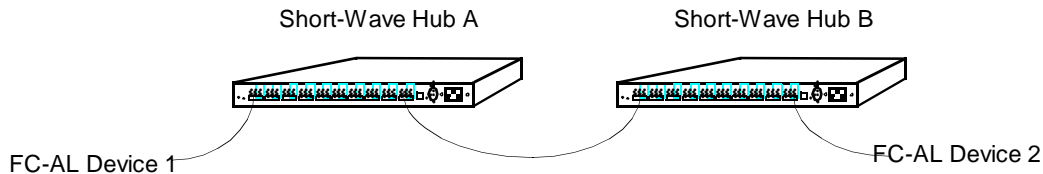

Note If you plan to use Fibre Channel Manager to manage cascaded hubs, you must configure the hub that has the LAN (ethernet) connection as a parent hub and the remaining hub as a child hub (see *Configuring Cascaded Hubs* on page 60).

Correct Cabling Example for a Long-Wave Hub

Hewlett-Packard recommends 9-micron, single-mode fiber cable for the long-wave port.

For ports 1 through 9, the short-wave ports, Hewlett-Packard recommends 50-micron multimode fiber cable for new installations but also supports 62.5-micron multimode fiber cable with SC-style connectors in existing installations.

In a cascaded configuration of FC-AL long-wave hubs, connect the long-wave port on the first hub to the long-wave port on the second hub. Figure 14 shows all 18 nodes in the loop formed by FC-AL Device 1, Hub A, Hub B, and FC-AL Device 2:

- Port 1 on Hub A connects to FC-AL Device 1.
- The long-wave port of Hub A connects to the long-wave port of Hub B.
- Port 1 on Hub B connects to FC-AL Device 2.

Long-wave hubs can be cascaded with ports 1 through 9 (the short-wave ports), but the supported distance between hubs is reduced from 3000 meters to 500 meters. When cascading long-wave hubs, **ONLY** connect long-wave ports to long-wave ports or short-wave ports to short-wave ports. Any unused short-wave port on Hub A or Hub B can connect to any compatible FC-AL device.

Figure 14 Cascaded Long-Wave Hub Configuration

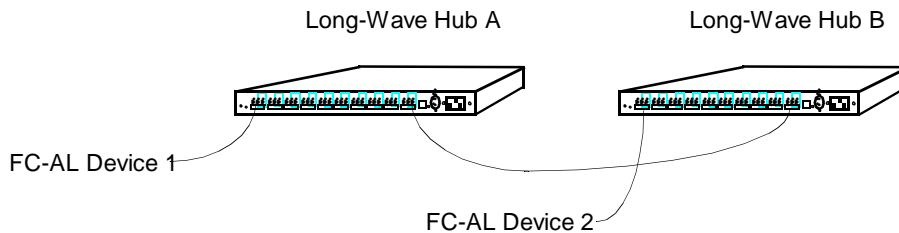

Note If you plan to use Fibre Channel Manager to manage cascaded hubs, you must configure the hub that has the LAN (ethernet) connection as a parent hub and the remaining hub as a child hub (see *Configuring Cascaded Hubs* on page 60).

Incorrect Cabling Examples

DO NOT cable together two ports on the same hub. Ports between the two connections will be eliminated from the loop.

Figure 15 Incorrect Cabling Example: Connected Ports on the Same Hub

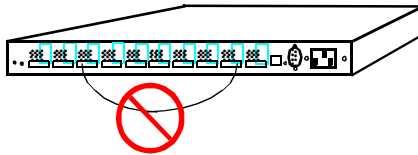

DO NOT leave cables that are connected to the hub disconnected at the opposite end of the cable.

Figure 16 Incorrect Cabling Example: Disconnected Cable

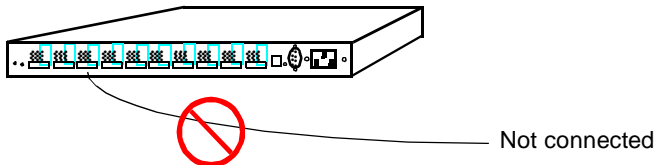

DO NOT attach more than one cable between any two hubs.

Figure 17 Incorrect Cabling Example: More Than One Cable Connection Between Hubs

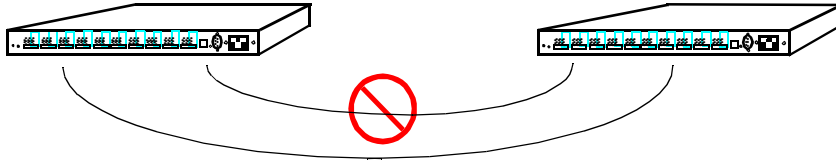

When cascading long-wave hubs, **DO NOT** connect the long-wave port to the short-wave port on another hub. **DO NOT** connect long-wave FC-AL devices to long-wave hubs.

Figure 18 Incorrect Cabling Example: Long-Wave Port Connections to Wrong Device/Port

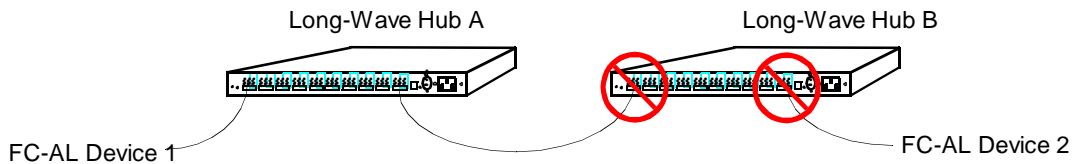

In the example in Figure 18:

- The long-wave port on Hub A is *incorrectly* connected to Port 1, a short-wave port, on Hub B.
- A device other than the long-wave port of another hub is attached to the long-wave port of Hub B.

The long-wave port of Hub A should be connected to the long-wave port of Hub B.

Nonsupported Cabling Example

Connecting a hub to more than one other hub is NOT a supported configuration.

Figure 19 Nonsupported Cabling Example: More Than Two Hubs Connected

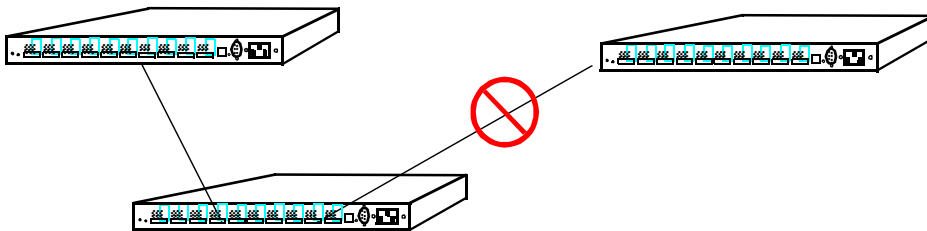

Connecting an HP-UX server and HP NetServer to the same hub is NOT a supported configuration.

Figure 20 Nonsupported Cabling Example: HP-UX Server and HP NetServer Connected to Same Hub

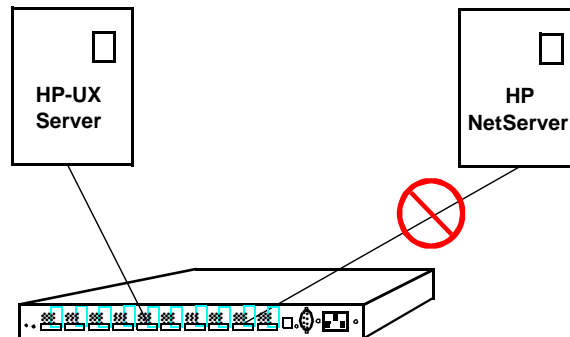

Procedure 6: Connect FC-AL Devices

After the hub and devices are prepared, connect FC-AL devices as follows:

1. Physically set each FC-AL device to a unique loop ID (hardware address). Refer to the FC-AL device's manual to set the loop ID.

If devices are added **during normal operation** and duplicate IDs occur, the Fibre Channel driver denies access to both devices until the address conflict is resolved. Change the address of the second (duplicating) device.

If devices are added or device addresses changed **while the system is powered off** and duplicate IDs occur, the system is unavailable until the address conflict is resolved. An error message appears on the system console. Change the address of the second (duplicating) device.

2. Remove the covers from the FC-AL ports. Refer to your cabling map, and begin connecting devices to the hub. Leave the covers on ports not in use.

Caution Fiber optic cables and connectors are extremely fragile. Avoid twisting or bending the cable beyond a 3-cm radius.

If the hub and all FC-AL devices are powered down, first plug in the hub, then power on the devices at all the FC-AL nodes on the loop. The hub should be the first operating component in the loop.

If the hub and all devices are powered up, you can connect the hub to a server or FC-AL device while the server or FC-AL device is operating.

If the hub is to be connected to an FC-AL adapter that is connected to another FC-AL device, follow the removal procedures in the document that came with the FC-AL device before disconnecting the device's cable.

If the hub is to be connected to an FC-AL device that is connected directly to a server, follow the removal procedures in the document that came with the FC-AL device before disconnecting the device's cable.

When installing model L10 long-wave hubs in a cascaded topology, make sure the long-wave port is connected only to the long-wave port on another long-wave hub.

3. For the model L10 long-wave hub, connect the long-wave loopback cable to the long-wave port if the port is not in use.
4. Install any special files the FC-AL devices need. Refer to the device manual for details.

Procedure 7: Verify the Connections

After connecting devices and the server to the hub, verify the connections.

Note Because the hub is strictly a pass-through device for FC-AL traffic, there is no hub address and the hub is not listed in `ioscan` output (HP-UX servers) or the **SCSI Adapters** window (HP NetServers).

For HP-UX servers:

1. Use the following HP-UX command to run `ioscan` and check the hardware paths between the server and the attached FC-AL devices:

`ioscan -f`

For details on `ioscan` and its options, refer to the *HP-UX System Administration Tasks Manual*. Also consult the device documentation to interpret the `ioscan` output.

2. If the Hardware State of a device connected to the hub is “Unclaimed” or “No H/W,” see chapter 4, Troubleshooting, for more information.

For HP NetServers:

1. From the **Start** menu, select **Settings**, then select **Control Panel**.
2. Double-click the **SCSI Adapters** icon. The SCSI Adapters window appears.
3. Click the **Devices** tab, then verify that the FC-AL devices connected to the hub are displayed.

3

RS-232 INTERFACE FUNCTIONS

Overview

Setting Up an RS-232 Connection

Updating the Hub Firmware

Enabling Hub Management

Running Diagnostic Tests

Viewing Hub Information

Overview

This chapter describes how to use the RS-232 port to update firmware, enable hub management, run diagnostic tests, and view hub information. The RS-232 port is located on the front panel of the hub (see Figure 1 on page 14 or Figure 2 on page 15).

To configure the hub for Fibre Channel Manager or another management application, use the hub's configuration menus to set SNMP values and the IP address.

If you do not plan to manage the hub with Fibre Channel Manager or another management application, you do not have to update the firmware or enable hub management. You do not have to update hub firmware to run diagnostic tests or view hub information.

Before beginning the procedures in this chapter, determine the configuration values that are required for the hub. Obtain IP addresses from the network administrator for the LAN to which the parent hub is connected. IP addresses are optional for the child hub. Values can be written in the spaces of the following worksheet.

Table 1 Worksheet for Hub Configuration

Parameter	Parent Hub	Child Hub (if any)
Firmware version (hub controller)		Same as parent
Firmware version (device agent)		Same as parent
Proxy master option	ENABLED	DISABLED
Port bypass persistence option	DISABLED	DISABLED
Hub IP address		
Subnet mask		
Default gateway address		
Trap IP address (optional, max. of 4)		
Trap IP address (optional, max. of 4)		
Trap IP address (optional, max. of 4)		
Trap IP address (optional, max. of 4)		

Table 1 Worksheet for Hub Configuration (cont'd)

Parameter	Parent Hub	Child Hub (if any)
SNMP get community name		
SNMP set community name		
SNMP trap community name		

About the RS-232 Main Menu

When you set up an RS-232 connection and boot the hub, the hub management Main menu appears on the terminal screen.

```

Fibre Channel Hub Model Number:      HP3724A
Device Agent Version:                 02.14
Hub Controller Version:               03.06
Agent Boot PROM Version:              01.04
Status of Device Agent self-test:     passed
Status of Hub Controller self-test:   passed

```

1. Reset hub and run self-test
2. Set Networking parameters
3. Management options
4. Hub information

The model and version numbers displayed can be different from the examples shown in this manual. Fewer menu options are displayed in earlier versions of the hub firmware. To update the firmware, follow the instructions given in Updating the Hub Firmware on page 48.

If the Main menu does not appear and the display shows the following message, press the Reset button on the front panel of the hub.

```
pROBE+>
```

The Main menu provides four options:

1. Reset hub and run self-test

This option resets the hub and runs the diagnostic tests. When changes are made to the hub, they do not take effect until the hub is reset.

2. Set Networking parameters

Use this option to view or change the hub network configuration, including the IP address. For cascaded hubs, use this option to define parent/child relationships.

3. Management options

This option displays a menu for changing SNMP values.

4. Hub information

Use this option to view the media access control (MAC) address and serial number.

Tips for Using the RS-232 Interface

- To enter a command, type the number that corresponds to the desired option, then press <ENTER>. An appropriate submenu appears.
- To enter a value, type the value and then press <ENTER>. To enter multiple values, enter each one separately.
- Enter **1** to return to the previous menu or option.
- From the Main menu, enter **1** to reset the hub. New self-test values are displayed after the hub has been reset.
- When you have finished making changes, you can close the terminal connection and disconnect the serial cable.

Setting Up an RS-232 Connection

The RS-232 interface requires a connection from the hub to a dumb terminal or to a PC with a terminal emulator program. A PC is required for updating firmware. To access the hub configuration menus, you can use either a PC or a dumb terminal.

Setting Up a Connection to a PC

Setting up a PC connection requires the following equipment:

- FC-AL hub
- A personal computer, such as an OmniBook notebook PC
- A null-modem serial cable

The cable must have a DB-9 female connector for connection to the hub. For example, for an OmniBook notebook PC, you can use an HP 24542U RS-232 cable, which has two DB-9 female connectors.

- Terminal emulation software, such as HyperTerminal

The terminal emulator must be capable of ASCII text file transfers and support VT100 or ANSI emulation with no flow control.

To establish a connection, do the following:

1. Connect the serial cable between the RS-232 port on the hub and a serial (COM) port on the PC.

-
2. Run the terminal emulator application. Configure the terminal emulator to use the following settings:

Baud rate:	19,200
Data bits:	8
Parity bits:	none
Stop bits:	1
Parity check:	off
Flow control:	none

3. Press <ENTER> to display the hub configuration Main menu.

If the Main menu does not appear and the following message is displayed, press the Reset button on the front panel of the hub:

```
pROBE+>
```

Setting Up a Connection to a Dumb Terminal

Setting up a connection between a dumb terminal and the hub requires the following equipment:

- FC-AL hub
- Any terminal that supports VT100 emulation with no flow control

The terminal must be in vt100 mode before you continue with this procedure. Refer to the terminal's manual for more information.

- A null-modem serial cable

The cable must have a DB-9 female connector for connection to the hub.

To establish a connection, do the following:

1. Connect the serial cable between the RS-232 ports on the hub and the terminal.
2. Power on the terminal.

-
3. Configure the terminal to use the following settings:

Baud rate:	19,200
Data bits:	8
Parity bits:	none
Stop bits:	1
Parity check:	off
Flow control:	none

4. Press <ENTER> to display the hub configuration Main menu.

If the Main menu does not appear and the following message is displayed, press the Reset button on the front panel of the hub.

pROBE+>

Updating the Hub Firmware

The hub's management tool, Fibre Channel Manager, requires the following versions of hub firmware: .

Device Agent	02.14 (or higher)
Hub Controller	03.06 (or higher)

Before you begin this procedure, determine whether the hub requires a firmware update to communicate with Fibre Channel Manager. A label on the bottom of the hub chassis lists the EDC datecode. If the EDC datecode is C-38XX or higher, the hub has the required firmware. If you are not able to access the label, determine the firmware versions by connecting to the hub's RS-232 interface (see Setting Up an RS-232 Connection on page 45).

To update the hub firmware, use a PC connected to the hub. First copy the firmware files to the PC and then transfer the firmware from the PC to the hub.

The general process for updating the hub firmware is the following:

1. Obtain the current firmware.
2. Reboot the hub.
3. Update the hub controller firmware.
4. Update the hub device agent code.
5. Reset the hub.
6. Set manufacturing values.

If any hubs are cascaded, repeat the procedures for each child hub. Parent and child hubs must have identical versions of the firmware.

The procedures in this section require a total of 30 to 60 minutes to complete.

Caution If a hub power failure occurs during the transfer of the new firmware to the hub, the hub can become inoperable.

Procedure 1: Obtain the Current Firmware

The current release of the hub firmware is available at the Hewlett-Packard Software Depot.

1. From a Netscape browser window, enter the URL for the Hewlett-Packard Software Depot (<http://www.software.hp.com>).
2. Click the **Network & Systems Administration** link, then click the **HP Fibre Channel Manager** link.
3. Click the **Download Hub firmware** link on the HP Fibre Channel Manager home page.

The firmware files are available as a self-extracting ZIP file for Windows and as a compressed tar file for HP-UX. These compressed files include the current and previous release version of the firmware. The previous release versions are necessary if you need to recover from an unsuccessful firmware update.

4. Follow the instructions at the web site to download the firmware files.
5. Copy the files to the PC you will use to download the new firmware files to the hub.

Procedure 2: Reboot the Hub

1. Set up an RS-232 connection as described in Setting Up a Connection to a PC on page 45.
2. After the hub configuration Main menu appears, enter **1** to reset the hub.

The screen begins to display the status of the hub. To reboot, you must interrupt the status display to go to the Boot menu.

3. Wait for the following message:

```
Press Enter key for Boot Menu, Agent boot in 6 seconds
```

-
4. Immediately press <ENTER> to display the Boot menu:

```
Boot menu V01.04
1. Download and update Device Agent code
2. Download and update Hub-Controller code
3. Reset hub and run self test
4. Start Normal Hub operation
```

Caution Do not update the device agent code at this time. The hub controller firmware must be updated first. The hub will not operate properly if the firmware is updated in the wrong sequence. See If Firmware Upgrade Appears to Fail on page 79 if the firmware is updated in the wrong sequence.

Procedure 3: Update the Hub Controller Firmware

1. From the Boot menu, enter **2** to update the hub controller firmware. A prompt appears for you to begin file transfer; for example:

```
Ready to download Hub-Controller code to RAM
Start ASCII file (S-record format) transfer now
<Refer to terminal emulator user manual for instructions>
Press control-C at any time to cancel
```

2. From the terminal emulator application, select the transfer option to send a text file. The hub's firmware files have a .frm suffix. Verify that the terminal emulator application is displaying all file types.
3. Send the following file you downloaded from the web site. (Firmware filenames change when updated versions are released. Always check the Hewlett-Packard Software Depot for the latest firmware version and download instructions.) The default directory for this file is C:\Temp\HUB_FW.

IFCH3820.FRM

Several rows of dots appear to indicate download progress; for example:

```
.....
.....
.....
```

After a few minutes, the transfer prompt appears; for example:

```
Done, memory range [$00001000:$00004FFF]
Ready to transfer Hub-Controller code from RAM to FLASH
Note, once started, this step must not be interrupted
Press Enter to start, control-C to cancel
```

The values displayed for memory range represent low-level diagnostics; the values displayed in the status message can be different from the values shown here.

4. Press <ENTER>. Additional progress indicators and status messages appear; for example:

```
--+
$......
*****
*****
```

The hub is automatically rebooted and additional messages appear:

```
DRAM test      (this will take about 10 seconds) > passed
SEEPROM test   (this will take about 1 second)  > passed
FLASH checksum (this will take about 2 seconds) > passed
Press Enter key for Boot Menu, Agent boot in 7 seconds
```

To reboot, you must interrupt the display to go to the Boot menu.

5. Immediately press <ENTER> to display the Boot menu.

Note

If the Main menu appears instead of the messages above, enter **1** to reboot the hub, then press <ENTER> before the timeout period is finished.

If the Main menu appears, ignore the Hub Controller version number. It may be blank or UNKNOWN. If the version number is blank or UNKNOWN, the upgrade version number will appear in the Main menu after you update the Hub Device Agent code and reset the hub.

Procedure 4: Update the Hub Device Agent Code

Caution The hub controller firmware must be updated before the device agent code. The hub will not operate properly if the firmware is updated in the wrong sequence. See If Firmware Upgrade Appears to Fail on page 79 if the firmware is updated in the wrong sequence.

1. From the Boot menu, enter **1** to update the device agent code. A prompt appears for you to begin file transfer; for example:

```
Ready to download Device Agent code to RAM
Start ASCII file (S-record format) transfer now
<Refer to terminal emulator user manual for instructions>
Press control-C at any time to cancel
```

2. From the terminal emulator application, select the transfer option to send a text file. The hub's firmware files have a .frm suffix. Verify that the terminal emulator application is displaying all file types.
3. Send the following file you downloaded from the web site. (Firmware filenames change when updated versions are released. Always check the Hewlett-Packard Software Depot for the latest firmware version and download instructions.) The default directory for this file is C:\Temp\HUB_FW.

IFCH3821.FRM

The screen is filled with rows of progress indicator dots as the file is transferred; for example:

```
.....
.....
.....
```

The transfer process can take 10 to 40 minutes. When the file transfer has been completed, status messages and a transfer prompt appear; for example:

```
Done, memory range [$00001000:$0005D666]
Ready to transfer Device Agent code from RAM to FLASH
Note, once started, this step must not be interrupted
Press Enter to start, control-C to cancel
```

The values displayed for memory range represent low-level diagnostics; the values displayed in the status message can be different from the values shown here.

4. Press <ENTER>. The screen displays status messages; for example:

```
FLASH programming will take about 40 seconds  
FLASH pgm:[$001000:$101000)->[$800000:$900000) >
```

Caution Do not interrupt the display or press any keys during this process.

After about 40 seconds, the display continues.

When FLASH programming is completed, the checksum appears; for example:

```
FLASH programming will take about 40 seconds  
FLASH pgm:[$001000:$101000)->[$800000:$900000) > complete, no errors  
New FLASH checksum = 0x7B04
```

The value displayed can be different from the example shown here. Then the Boot menu appears again.

Procedure 5: Reset the Hub

After updating the hub firmware, you must reset the hub for the new firmware to take effect.

1. From the Boot menu, enter **3** to reset the hub and run the hub self-test. The Main menu appears and displays the new hub controller and device agent code version numbers.
2. Verify that the upgrade version numbers are displayed, then go to Procedure 6: Set Manufacturing Values.

If the Main menu displays the Hub Controller version as `Unknown`, continue with step 3.

-
- From the Main menu, enter **2** (Set Networking parameters) to display the Network Setup menu.

Network Setup Menu:

- Return to Main Menu
- Select IP address [current = nnn.nnn.nnn.nnn]
- Select Subnetworking Mask [current = nnn.nnn.nnn.nnn]
- Select Default Gateway address [current = nnn.nnn.nnn.nnn]
- Save Network Setup changes and reboot
- Proxy Master Setup

- Enter **6** to display the Proxy Master menu:

Proxy Master Menu: <Current state: Proxy Master DISABLED>

- Return to previous Menu
- Toggle current Proxy Master state and reboot

- Enter **2** to change the Proxy Master setting to `ENABLED` and reboot the hub. When the Main menu appears, verify the new Hub Controller version.

Procedure 6: Set Manufacturing Values

After resetting the hub and verifying the new firmware versions, set the *system.sysDescr* and *system.sysObjectID* values.

- From the Main menu, enter **mfg** to display the Manufacturing Settings Menu.

Manufacturing Settings Menu:

- Return to Main Menu
 - Set sysdescr [current =]
 - Set system OID [current = 1.3.6.1.4.1]
 - Toggle port bypass persistence mode [current = Enabled]
- >

- Enter **2** to display the Set sysDescr string Menu.

Set sysDescr string Menu: [current =]

- Return to Manufacturing Settings Menu
or enter new sysDescr string
- >

-
3. For the model S10 short-wave hub, enter: **HP A3724A FC-AL Shortwave Hub**

For the model L10 long-wave hub, enter: **HP A4839A FC-AL Longwave Hub**

The Set sysDescr string Menu appears with the new setting. (The following example is for the short-wave hub.)

```
Set sysDescr string Menu: [current = HP A3724A FC-AL Shortwave Hub]
```

1. Return to Manufacturing Settings Menu
or enter new sysDescr string
>
4. Verify that the setting is correct, then enter **1** to return to the Manufacturing Settings Menu.

```
Manufacturing Settings Menu:
```

1. Return to Main Menu
 2. Set sysdescr [current = HP A3724A FC-AL Shortwave Hub]
 3. Set system OID [current = 1.3.6.1.4.1]
 4. Toggle port bypass persistence mode [current = Enabled]
>
5. Enter **3** to display the Set System OID Menu.

```
Set System OID Menu: [current = 1.3.6.1.4.1]
```

1. Return to Manufacturing Settings Menu
or enter new system OID suffix in dotted decimal format
The suffix entered will be appended to 1.3.6.1.4.1
example: if desired system OID is 1.3.6.1.4.1.2.3.4, then enter
2.3.4
>
6. Enter **11.2.3.7.5.10**

The Set System OID Menu appears with the new setting.

```
Set System OID Menu: [current = 1.3.6.1.4.1.11.2.3.7.5.10]
```

```
1. Return to Manufacturing Settings Menu
or enter new system OID suffix in dotted decimal format
The suffix entered will be appended to 1.3.6.1.4.1
example: if desired system OID is 1.3.6.1.4.1.2.3.4, then enter
2.3.4
>
```

7. Verify that the setting is correct, then enter **1** to return to the Manufacturing Settings Menu.

```
Manufacturing Settings Menu:
1. Return to Main Menu
2. Set sysdescr [current = HP A3724A FC-AL Shortwave Hub]
3. Set system OID [current = 1.3.6.1.4.1.11.2.3.7.5.10]
4. Toggle port bypass persistence mode [current = Enabled]
>
```

If you are using Fibre Channel Manager to manage the hub, the bypass persistence setting controls the behavior of bypassed ports when the hub is power cycled or reset.

If the hub is power-cycled or reset with bypass persistence disabled, the hub automatically enables all ports that were previously bypassed in Fibre Channel Manager. If the hub is reset with bypass persistence enabled, the hub continues to bypass ports that were bypassed in Fibre Channel Manager.

8. Enter **4** to disable port bypass persistence. Verify that the port bypass persistence mode is disabled.

```
Manufacturing Settings Menu:
1. Return to Main Menu
2. Set sysdescr [current = HP A3724A FC-AL Shortwave Hub]
3. Set system OID [current = 1.3.6.1.4.1.11.2.3.7.5.10]
4. Toggle port bypass persistence mode [current = Disabled]
>
```

9. Enter **1** to return to the Main menu.
10. Exit the terminal emulator application and disconnect the serial cable from the hub and the PC.

Enabling Hub Management

Use the hub RS-232 management menus to enable the hub to be managed by Fibre Channel Manager. To enable hub management:

- Set hub IP address and network configuration options.
- Set SNMP values.
- Configure cascaded hubs (if you plan to manage hubs in a cascaded configuration).

Setting Hub IP Address and Network Configuration Options

Use this procedure to set the following parameters on the hub.

- Hub IP address
- Subnetworking mask
- Default gateway address

If you have hubs in a cascaded configuration, only perform this procedure for the parent hub. The parent hub should be the hub that has the LAN (ethernet) connection. Refer to the values you entered in Table 1 on page 42 as you set the above parameters.

To set hub IP address and network configuration options:

1. Set up an RS-232 connection between the parent hub and a PC or dumb terminal (see Setting Up a Connection to a PC on page 45 or Setting Up a Connection to a Dumb Terminal on page 46).

-
- From the Main menu, enter **2** (Set Networking parameters) to display the Network Setup menu:

Network Setup Menu:

- Return to Main Menu
 - Select IP address [current = nnn.nnn.nnn.nnn]
 - Select Subnetworking Mask [current = nnn.nnn.nnn.nnn]
 - Select Default Gateway address [current = nnn.nnn.nnn.nnn]
 - Save Network Setup changes and reboot
 - Proxy Master Setup
- Enter **2** to set the hub IP address. A command prompt appears.
 - Type the IP address for the hub, then press **<ENTER>**.
 - Enter **3** to set the Subnetworking Mask. A command prompt appears.
 - Type the Subnetworking Mask for the hub, then press **<ENTER>**.
 - Enter **4** to set the Default Gateway address. A command prompt appears.
 - Type the Default Gateway address for the hub, then press **<ENTER>**.
 - Enter **5** to save your changes. The hub is rebooted with the new values. The Main menu appears.

Caution You must enter **5** to save changes. If you do not want to change the hub values, do not enter **5**. Instead, enter **1** to return to the Main menu.

Verifying and Setting SNMP Values

Use the following procedure to set the following SNMP values. If you have hubs in a cascaded configuration, only perform this procedure for the parent hub. The parent hub should be the hub that has the LAN (ethernet) connection. Refer to the values you entered in Table 1 on page 42 as you set the above parameters.

- get community name

The get community name must be the same name used when a device was added to Fibre Channel Manager. If the names are not identical, Fibre Channel Manager cannot report management information for this hub. The default value is **public**.

- set community name

The set community name must be the same name used when a device was added to Fibre Channel Manager. If the names are not identical, Fibre Channel Manager cannot set management parameters for this hub. The default value is **private**.

- SNMP trap community name

The hub includes the trap community name in event messages sent to the management application. The default value is **SNMP_trap**.

- trap server IP addresses

This option sets the destination addresses for SNMP event messages. A maximum of four addresses can be specified.

Caution If you enter the name of an existing IP address, the existing address is deleted.

- MIB-2 system name

This value is returned for the SNMP MIB-2 *system.sysName* variable.

- default values

This option resets the get, set, and trap community names to the default values.

To verify and set SNMP values, do the following:

1. Verify with your network administrator that the default get community name is acceptable. The default is **public**.
2. Verify with your network administrator that the default set community name is acceptable. The default is **private**.
3. Verify with your network administrator that the default trap community name is acceptable. The default is **SNMP_trap**.

-
- From the Main menu, enter **3** (Management options) to display the Management Options menu:

Management options Menu:

- Return to Main Menu
 - Set SNMP get community name
 - Set SNMP set community name
 - Set SNMP trap community name
 - Set SNMP trap server IP addresses
 - Set MIB-2 sysname
 - Restore default values to SNMP get, set, trap community names
 - Clear SNMP trap server IP address list
- Enter **5** to set the IP address(es) where you want Fibre Channel Manager to send traps (optional). The Set Trap IP address Menu appears.
 - Type the trap server IP address, then press **<ENTER>**.
To enter additional addresses, repeat step 6. You can enter up to four IP addresses.
To delete an existing trap server IP address, enter the value of the existing IP address.
 - Enter **1** to return to the Management Options menu.
 - Enter **6** to set the MIB-2 sysname (optional). The SNMP MIB-2 sysName Menu appears.
 - Type a unique name for the hub, then press **<ENTER>**.
 - Enter **1** to return to the Management Options menu, then enter **1** again to return to the Main menu.

Configuring Cascaded Hubs

By default, HP SureStore E hubs are configured as parent hubs. However, you can connect two hubs in a cascaded configuration in which one hub (the parent) is connected to the LAN (ethernet) and the other hub (the child) is connected to the parent hub. For information about setting up a cascaded hub configuration, see page 18 and page 32.

Configuring the Parent Hub

If you plan to manage cascaded hubs with Fibre Channel Manager, configure the hub connected to the LAN as a parent hub.

1. From the Main menu, enter **2** (Set Networking parameters) to display the Network Setup menu.

Network Setup Menu:

1. Return to Main Menu
2. Select IP address [current = nnn.nnn.nnn.nnn]
3. Select Subnetworking Mask [current = nnn.nnn.nnn.nnn]
4. Select Default Gateway address [current = nnn.nnn.nnn.nnn]
5. Save Network Setup changes and reboot
6. Proxy Master Setup

2. Enter **6** to display the Proxy Master menu:

Proxy Master Menu: <Current state: Proxy Master ENABLED>

1. Return to previous Menu
2. Toggle current Proxy Master state and reboot

For the parent hub, verify that the master is `ENABLED`, then enter **1** to return to the Network Setup menu. Enter **1** again to return to the Main menu.

3. Enter **5** to save your changes. The hub is rebooted with the new values.
4. Close the terminal connection and disconnect the serial cable.

Configuring the Child Hub

If you plan to manage cascaded hubs with Fibre Channel Manager, configure the hub that is connected to the parent hub as a child hub.

1. Set up an RS-232 connection between the child hub and a PC or dumb terminal (see [Setting Up a Connection to a PC on page 45](#) or [Setting Up a Connection to a Dumb Terminal on page 46](#)).

-
- From the Main menu, enter **3** (Management options) to display Management Options menu:

Management options Menu:

- Return to Main Menu
 - Set SNMP get community name
 - Set SNMP set community name
 - Set SNMP trap community name
 - Set SNMP trap server IP addresses
 - Set MIB-2 sysname
 - Restore default values to SNMP get, set, trap community names
 - Clear SNMP trap server IP address list
- Enter **6** to set the MIB-2 sysname for the child hub (optional).
 - Type a unique name for the child hub, then press **<ENTER>**.
 - Enter **1** to return to the Management Options menu, then enter **1** again to return to the Main menu.
 - From the Main menu, enter **2** (Set Networking parameters) to display the Network Setup menu.

Network Setup Menu:

- Return to Main Menu
 - Select IP address [current = nnn.nnn.nnn.nnn]
 - Select Subnetworking Mask [current = nnn.nnn.nnn.nnn]
 - Select Default Gateway address [current = nnn.nnn.nnn.nnn]
 - Save Network Setup changes and reboot
 - Proxy Master Setup
- From the Network Setup menu, enter **6** to display the Proxy Master menu:

Proxy Master Menu: <Current state: Proxy Master ENABLED>

- Return to previous Menu
 - Toggle current Proxy Master state and reboot
- To disable the proxy master option (configure the hub as a child), enter **2**. The hub is rebooted automatically and the Main menu reappears.

To verify that the hub is configured as a child, return to the Proxy Master menu. The proxy master state for a child hub is displayed as “DISABLED.”

-
9. Close the terminal connection and disconnect the serial cable from the child hub.

Connecting the Hubs

Connect the parent hub to the child hub. See page 32 to connect short-wave hubs and page 33 to connect long-wave hubs. See page 17 for information on supported cascaded topologies.

Running Diagnostic Tests

When a problem occurs in the hub, the amber Fault LED comes on. A fault can occur for many reasons, including:

- Elevated internal temperature
- Power supply failure
- Fan malfunction

To determine the cause of the problem, run the hub self-test from the Main menu.

1. Set up an RS-232 connection between the hub and a PC or dumb terminal (see Setting Up a Connection to a PC on page 45 or Setting Up a Connection to a Dumb Terminal on page 46).
2. From the Main menu, enter **1** to reset the hub and run the self-test. If the hub fails the self-test, an error number is displayed; for example:

```
Status of Hub Controller self-test:      0200
```

A value of 0200 in the self-test represents a fan failure. Replace the fan module as described in Replacing the Fan Module on page 88.

Any other numeric value represents an internal hub failure. Internal parts are not replaceable. If an internal malfunction occurs, replace the hub.

WARNING **Do not attempt to open the hub chassis. Uninsulated parts inside the chassis constitute a hazard.**

3. After correcting any problems, enter **1** to reset the hub.

For normal hub operation, the Hub Controller self-test status is displayed as “passed.” For a child hub, the Hub Controller self-test status is displayed as “Unknown.”

Viewing Hub Information

Use the Hub Information menu to view the following hub identification information:

- MAC address
- Child device
- Serial number

To view hub information:

1. From the Main menu, enter **4** (Hub Information) to display the MAC address. The MAC address and the Hub Information menu appear; for example:

```
MAC address: 0060b0-5e0827
```

1. Return to previous Menu
2. Display list of proxied devices

The MAC address is unique for each hub and cannot be changed.

2. To display additional information, enter **2**. This option displays the serial number of the hub and any child hub connected to it; for example:

1. Local Hub-Controller: Model#:HP A3724A, Serial#:usg1001028, Ver:03.06
2. Remote Hub-Controller: Model#:HP A3724A, Serial#:usg1001023, Ver:03.06

Item 1 represents information for the hub, including model number and hub controller firmware version number. If another hub is cascaded to this hub, information about the child hub is displayed as item 2. A child hub appears only if the Proxy Master parameter is enabled and the ports of the two hubs are connected.

For instructions on how to configure a hub as a child hub, see [Configuring the Child Hub](#) on page 61.

3. To return to the Main menu, enter **1**.



Troubleshooting Procedures

LED Indicators

If the Power LED Is Off

If the Hub Fault LED Stays on After Self-Test

If a Fan Is Not Operating

If a Device Is Unlisted/UNCLAIMED in ioscan or Not Displayed in SCSI Adapters Window

If a Port LED Is Off

If a Port LED Is On When It Should Be Off

If the Management Server Cannot Ping the Hub

If Firmware Upgrade Appears to Fail

Troubleshooting Procedures

If there is a problem accessing a device connected to the hub, the source of the problem can be with the device, the hub, the host, or any of the connections between the host and the device. Follow the steps below to investigate the problem from the most likely to the least likely cause. In addition, check the troubleshooting tables in this chapter for solutions to specific symptoms.

1. **For HP-UX servers**, run `ioscan` from the server's console.
 - If the hardware paths for all FC-AL devices connected to the hub are listed in `ioscan`, the connection from the host to the device is good, and problems accessing a device probably originate in the software, driver, or device.
 - If the hardware path for a FC-AL device connected to the hub is not listed in `ioscan`, the source of the problem is likely to be bad connections, duplicate hardware addresses, a faulty device, or a faulty hub (see steps 2 through 5). *The hub does not appear in ioscan output because it does not have a hardware address.*

For HP NetServers, open the **SCSI Adapters** window, then click the **Devices** tab. If the device is not displayed, the problem is likely to be bad connections, duplicate hardware addresses, a faulty device, or a faulty hub (see steps 2 through 5). *The hub does not appear in this window because it does not have a hardware address.*

2. **Inspect the cabling between the hub and FC-AL devices.** Check for loose, dirty, broken, or bent cabling and connectors. Cables should attach with an audible click.
3. **Check the loop ID (hardware address) of each device on the loop and eliminate any duplicate addresses.** Reset the hub after changing any loop ID, then run `ioscan` to make sure there are no duplicate addresses. Duplicate addresses can be indicated by “NO H/W” in the S/W State field.
4. **Inspect the FC-AL device for a fault.** Follow the instructions that came with the device. Make sure you check the fiber optic transmit or receiving port on the device.
5. **Inspect the hub LED indicators for apparent problems** (see Table 2 on page 70). If the Fault LED is lit, either the fans or the hub is faulty. If a cable is connected to a port

and the corresponding port LED is not lit, try replacing the cable with a loopback cable to determine if the problem is with the cable or the port. *For the long-wave hub, use the long-wave loopback cable (A4839-63001) if you are testing the long-wave port.*

LED Indicators

Table 2 LED Indications

Label	LED Pattern and Color	Indication	Possible Causes
Power	steady – green	Hub is powered on.	Normal state
	flashing - green	Power is intermittent.	<ul style="list-style-type: none"> – Fibre Channel Manager is set to beacon (flash) the Power LED (normal state). – Line voltage is inadequate. – Hub is faulty.
	blank – off	No power to hub.	<ul style="list-style-type: none"> – Line has no voltage. – Hub is disconnected, or power cable is bad. – Hub is faulty.
Fault	steady – amber	Hub is running self-test. If light remains on after 20 seconds, hub failed self-test.	If self-test fails, hub detected either: <ul style="list-style-type: none"> – A faulty fan module – A faulty hub
	blank – not on	Self-test completed or power is off. (Power LED is also off.)	Normal running or off state
Ports 1-10	steady – green	FC-AL connection to this port is valid.	Normal state for a connected port
	blank – not on	Port for this LED is inactive.	Port is being bypassed because: <ul style="list-style-type: none"> – Port is not connected to another device. – Port was bypassed in Fibre Channel Manager. – Attached FC-AL device is faulty or turned off. – Port is faulty. – Cable or connector is faulty.

Table 2 LED Indications (cont'd)

Label	LED Pattern and Color	Indication	Possible Causes
10Base-T	flashing – green	Ethernet connection to hub is valid.	Normal state

If the Power LED Is Off

If the Power LED is off, find the symptom that best fits the situation, then attempt the solution. When more than one solution is possible, the most likely one is listed first.

Symptom	Cause/Solution
The hub is installed, but the Power LED is off.	The power cord is not connected at both ends. Plug the power cord in at the hub and the power source.
The power cord is plugged in, but the Power LED is off.	<ul style="list-style-type: none">– The line voltage is inadequate. Reactivate or adjust line voltage.– The power cord is bad. Replace the power cord.– The hub is faulty. Replace the hub.

If the Hub Fault LED Stays on After Self-Test

If the hub Fault LED stays on after the self-test is complete, find the symptom that best describes the situation, then attempt the solution. When more than one solution is possible, the most likely one is listed first.

Symptom	Cause/Solution
The host can access devices, but the hub Fault LED stays on after self-test.	<ul style="list-style-type: none">– One or more fans are faulty. Replace the fan module. <i>Although the module will continue to run with two fans, a full complement of fans ensures system and data integrity.</i>– The hub is experiencing an internal temperature or memory fault. Replace the hub.
The host cannot access devices, and the Fault LED stays on after self-test.	<ul style="list-style-type: none">– The hub is faulty. Replace the hub.

If a Fan Is Not Operating

If one or more fans stop, find the symptom that best describes the situation, then attempt the solution. When more than one solution is possible, the most likely one is listed first.

Symptom	Cause/Solution
The host can access devices, the Fault LED stays on after self-test, and one or more fans have stopped.	<ul style="list-style-type: none">– One or more of the fans are blocked or obstructed. Verify that the fans are not blocked or obstructed.– The fan module is not firmly seated. Reinstall the fan module.– The fans are faulty. Replace the fan module.

If a Device Is Unlisted/UNCLAIMED in ioscan or Not Displayed in SCSI Adapters Window

If ioscan (HP-UX server) does not list a device connected to the hub or shows the status of the device as UNCLAIMED or NO H/W, or if the SCSI Adapters window (HP NetServer) does not display a device connected to the hub, the problem may be with the device, the hub, the host, or the connections between them. Find the combination of symptoms below that best describes the situation, then attempt the solution. When more than one solution is possible, the most likely is listed first. *The hub does not appear in ioscan output or the SCSI Adapters window because it does not have a hardware address.*

Symptom	Cause/Solution
The Port LED for the host or the device is off, and ioscan does not list the device.	<ul style="list-style-type: none">– The connection between the device or host and the hub is faulty. See If a Port LED Is Off on page 76.– The host's FC adapter is faulty. Replace the adapter.– The FC device is faulty. Replace the device.
The Port LED is on, and ioscan does not list the device.	There is a duplicate hardware address on the FC-AL loop. Verify that all devices on the loop have unique IDs, then reset the hub.
The Port LED is on, and ioscan Class is "UNKNOWN."	The software driver is missing on the host. Replace the device driver file.
The Port LED is on, and ioscan shows the S/W State as "UNCLAIMED" or "NO H/W."	<ul style="list-style-type: none">– The device has a duplicate address with another device on the loop. Change the address of one of the devices to a unique address. (The device may need to be powered off and on to reset the address.)– The software driver for the device is incorrect on the host. Replace the device driver file on the system.– The device is faulty. Troubleshoot the device using the instructions that came with the device. Be sure to check the fiber optic transmit or receiving port on the device.
The hub Fault LED is on, and ioscan does not list the device.	The hub is faulty. Replace the hub.

If a Port LED Is Off

If *a* Port LED is off where a cable is connected, find the symptom that best describes the situation, then attempt the solution. When more than one solution is possible, the most likely one is listed first.

If *all* port LEDs are off where cables are connected, see If Firmware Upgrade Appears to Fail on page 79.

Symptom	Cause/Solution
The host cannot access the device, and the Port LED is off.	<ul style="list-style-type: none">– The port is bypassed in Fibre Channel Manager. If you are using Fibre Channel Manager to manage the hub, verify that the port in question is enabled. (See the <i>HP Fibre Channel Manager User Manual</i> for more information.)– The device is faulty or offline. Verify that the device is turned on and has successfully completed its self-test.– The device is incompatible with the hub. Replace with a non-OFC, short-wave, 1063-Mbps FC-AL device.
The device is good, and the Port LED comes on when a loopback cable is connected to the hub port.	<ul style="list-style-type: none">– The cable is incompatible with the hub. Replace the cable with a 50 or 62.5-micron multimode fiber optic cable.– A short-wave port is connected to the long-wave port on another hub. When cascading hubs, only connect long-wave ports to long-wave ports and short-wave ports to short-wave ports. Reconnect the hubs accordingly.– The connector is dirty. Clean both ends of the cable with high purity alcohol and wipe with a soft, lint-free cloth (see chapter 5, Maintenance and Replacement).– The cable is bent or broken. Replace the cable.
The Port LED remains off when a loopback cable is connected to the hub port.	<ul style="list-style-type: none">– The hub port is dirty. Try cleaning the port by gently blowing with clean, dry compressed air (see chapter 5, Maintenance and Replacement). Reattach the loopback cable and see if the Port LED is on.– The hub port is faulty. Replace the hub.

If a Port LED Is On When It Should Be Off

If a Port LED is on when no active device is attached, find the symptom that best fits the situation, then attempt the solution. When more than one solution is possible, the most likely one is listed first.

Symptom	Cause/Solution
The cable has been disconnected at the device or is connected to an inactive device, and the Port LED is on.	The cable is still connected to a functional device. Check the Fibre Channel mass storage device map to verify that the device is connected to the port. Also look for a Port LED that is off but should be on. Change the connections or change the map as needed.
Port LED stays on after the cable is disconnected from the port.	The hub is faulty. Replace the hub.

If the Management Server Cannot Ping the Hub

If you cannot ping the hub from the management server (host) where Fibre Channel Manager is or will be installed, find the symptom that best fits the situation, then attempt the solution. When more than one solution is possible, the most likely one is listed first.

Symptom	Cause/Solution
You cannot ping the hub and the hub's 10Base-T port LED is off.	<p>The ethernet cable is not connected properly. Verify that the ethernet cable is securely connected to the hub and the management server.</p> <p>The ethernet cable is faulty. Connect another ethernet cable between the management server and hub.</p>
You cannot ping the hub and the hub's 10Base-T port LED is on.	<p>The IP address used to ping the hub is incorrect. Verify that you typed the correct IP address when pinging the hub.</p> <p>One or more of the hub's addresses are incorrect. Display the hub's serial interface as described in chapter 3, RS-232 Interface Functions. Verify that the hub's IP, subnetworking mask, and default gateway addresses are correct.</p> <p>If you do not enter 5. Save Network Setup changes and reboot, the addresses you enter are not saved.</p>

If Firmware Upgrade Appears to Fail

The hub management menus and Boot menu require a serial interface through the RS-232 port of the hub.

Symptom	Cause/Solution
<ul style="list-style-type: none">– During firmware upgrade, the following message appears every 1 minute and 45 seconds: Hub-Controller version: 03.06 is now loaded into RAM– After firmware upgrade, “Hub Controller Version” and “Status of Hub Controller self-test” are blank on Main menu.– All port LEDs are off.– The hub is inoperable.	<p>The hub device agent code and hub controller firmware are not compatible. Incompatibility can occur when:</p> <ul style="list-style-type: none">– The device agent code was installed in the incorrect order.– Firmware transfer was interrupted during the update procedure.– Only one firmware file was updated. <p>The hub controller firmware must be updated <i>before</i> updating the hub device code. <i>Both</i> files must be updated. Reinstall the prior version of the firmware as described in the following section. Then follow the update procedures provided in Updating the Hub Firmware on page 48.</p>
<p>The terminal screen does not display a prompt.</p>	<p>The serial port is not connected. Verify that the serial cable is connected to the correct ports.</p> <p>The cable is not a null-modem cable. Verify that the cable connected to the RS-232 port is a null-modem cable.</p> <p>The terminal or terminal emulator is not configured correctly. Verify that the terminal or terminal emulator is configured as described on page 46.</p>
<p>“pROBE+>” appears instead of the Main menu.</p>	<p>The hub firmware is experiencing temporary difficulty. Reset the hub, and verify that the Main menu appears.</p>

Recovering from Failed Firmware Upgrade

To recover from firmware upgrade difficulties, you must first reinstall the previous versions of firmware, then upgrade to the new version of firmware. The previous versions of firmware were included in the compressed file you downloaded from the Hewlett-Packard Software Depot (<http://www.software.hp.com>).

1. Connect a serial cable to the hub RS-232 port and configure the terminal emulator (see *Setting Up a Connection to a PC* on page 45).
2. Press the Reset button on the front panel of the hub.

The terminal emulator screen begins to display the status of the hub. To reboot, you must interrupt the status display to go to the Boot menu.

3. Wait for the following message:

```
Press Enter key for Boot Menu, Agent boot in 6 seconds.
```

4. Immediately press <ENTER> to display the Boot menu:

```
Boot menu V01.04
1. Download and update Device Agent code
2. Download and update Hub-Controller code
3. Reset hub and run self test
4. Start Normal Hub operation
```

Reinstalling the Hub Device Agent Code

1. From the Boot menu, enter **1** to update the device agent code. A prompt appears for you to begin file transfer; for example:

```
Ready to download Device Agent code to RAM
Start ASCII file (S-record format) transfer now
<Refer to terminal emulator user manual for instructions>
Press control-C at any time to cancel
```

2. From the terminal emulator application, use the transfer option to send a text file. The appropriate file was previously downloaded as a compressed file from the Hewlett-Packard Software Depot (<http://www.software.hp.com>).

For model S10 short-wave hubs, send the following file:

```
IFCH3719.FRM
```

For model L10 long-wave hubs, send the following file:

```
IFCH3720.FRM
```

The screen is filled with rows of progress indicator dots as the file is transferred; for example:

```
.....
.....
.....
.....
```

The transfer process can take 10 to 40 minutes.

When the file transfer has been completed, status messages and a transfer prompt appear; for example:

```
Done, memory range [$00001000:$0005B666]
Ready to transfer Device Agent code from RAM to FLASH
Note, once started, this step must not be interrupted
Press Enter to start, control-C to cancel
```

The values displayed for memory range represent low-level diagnostics. The values displayed in the status message can be different from the values shown here.

-
3. Press <ENTER>. The screen displays status messages; for example:

```
FLASH programming will take about 40 seconds
FLASH pgm:[$001000:$101000)->[$800000:$900000) >
```

Caution Do not interrupt the display or press any keys during this process.

After about 40 seconds, the display continues.

When FLASH programming is completed, the checksum appears; for example:

```
FLASH programming will take about 40 seconds
FLASH pgm:[$001000:$101000)->[$800000:$900000) > complete, no errors
New FLASH checksum = 0x12FC
```

The value displayed can be different from the example shown here. Then the Boot menu appears again.

Reinstalling the Hub Controller Firmware

1. From the Boot menu, enter **2** to update the hub controller firmware.
2. From the terminal emulator application, select the transfer option to send a text file. The screen displays status messages and progress indicators; for example:

```
Ready to download Hub-Controller code to RAM
Start ASCII file (S-record format) transfer now
<Refer to terminal emulator user manual for instructions>
Press control-C at any time to cancel
```

3. Send the following file you previously downloaded from the Hewlett-Packard Software Depot:

IFCH3718.FRM

Several rows of dots appear to indicate download progress; for example:

```
.....
.....
.....
.....
```

After a few minutes, the transfer prompt appears; for example:

```
Done, memory range [$00001000:$00004FFF]
Ready to transfer Hub-Controller code from RAM to FLASH
Note, once started, this step must not be interrupted
Press Enter to start, control-C to cancel
```

The values displayed for memory range represent low-level diagnostics; the values displayed in the status message can be different from the values shown here.

4. Press <ENTER>. Additional progress indicators and status messages appear; for example:

```
--+
$. . . . .
. . . . .
*****
```

The hub is automatically rebooted and additional messages appear:

```
Rebooting to make sure download was successful...

DRAM test      (this will take about 10 seconds)  > passed
SEEPROM test   (this will take about 1 second)   > passed
FLASH checksum (this will take about 2 seconds) > passed
Press Enter key for Boot Menu, Agent boot in 6 seconds
```

Then the Main menu appears.

```
Fibre Channel Hub Model Number:      HP3724A
Device Agent Version:                 02.04
Hub Controller Version:               02.02
Agent Boot PROM Version:              01.04
Status of Device Agent self-test:     passed
Status of Hub Controller self-test:   passed
```

1. Reset hub and run self-test
2. Set Networking parameters

5. Verify that the Device Agent and Hub Controller versions you reinstalled appear in the Main menu.
6. See Updating the Hub Firmware on page 48 to upgrade to the new firmware versions.



5

MAINTENANCE AND REPLACEMENT

Introduction

Maintenance

Replacing the Fan Module

Introduction

This chapter explains how to maintain the hub and replace the fan module. The fan module is the only replaceable part on the hub. To identify the source of a problem, see chapter 4, Troubleshooting.

WARNING **Do not attempt to open the hub chassis. Uninsulated parts inside the chassis constitute a hazard.**

Maintenance

Good system performance requires clean port optics and cable ferrules to avoid obstructing the optical path. The following preventive maintenance will protect the hub for longer use.

- Vacuum to remove dust.
- Leave the FC port covers on unused FC ports.
- Replace the fan module every three years.
- Avoid dropping fiber optic cable ends. This can cause internal glass fractures and intermittent signals.
- Keep unused cable ends covered to avoid contaminant-obscured or attenuated light signals.
- Never insert foreign objects into the optical transmit and receive ports.
- Avoid bending fiber cables over more than a 3-cm bend radius.

When a faulty connection is suspected, blowing clean compressed air on the FC port and cable end often is sufficient to remove dirt particles. Cleaning the connectors with methanol on a lint-free cloth is also effective. Alcohols that can be used include methyl, isopropyl, and isobutyl. Other acceptable substances for cleaning fiber optics are hexane and heptane aliphatics, soap solution, and naphtha.

Caution DO NOT use partially halogenated hydrocarbons, ketones, acetone, chloroform, ethyl acetate, methylene dichloride, phenol, methylene chloride, or N-methylpyrrolidone to clean the connectors.

Replacing the Fan Module

The three fans in the fan module operate in parallel. If one fan fails, the other two will continue to operate. However, it is important to replace the fan module immediately. Replace the fan module at least once every three years.

You will need the following tools:

- Standard Phillips screwdriver
- Fan module (A3724-60002)

WARNING **The power cord is the main disconnect for this product. To protect against hazard, always unplug the AC power cord before removing the fan module.**

1. Relocate or power off devices connected to the hub as needed to prepare for powering off the hub.
2. Unplug the power cord from the hub.
3. Using a standard Phillips screwdriver, remove the four screws that secure the fan module. Sheet metal marks indicate the location of the screws on the top and sides of the hub.

Figure 21 Removing the Fan Module

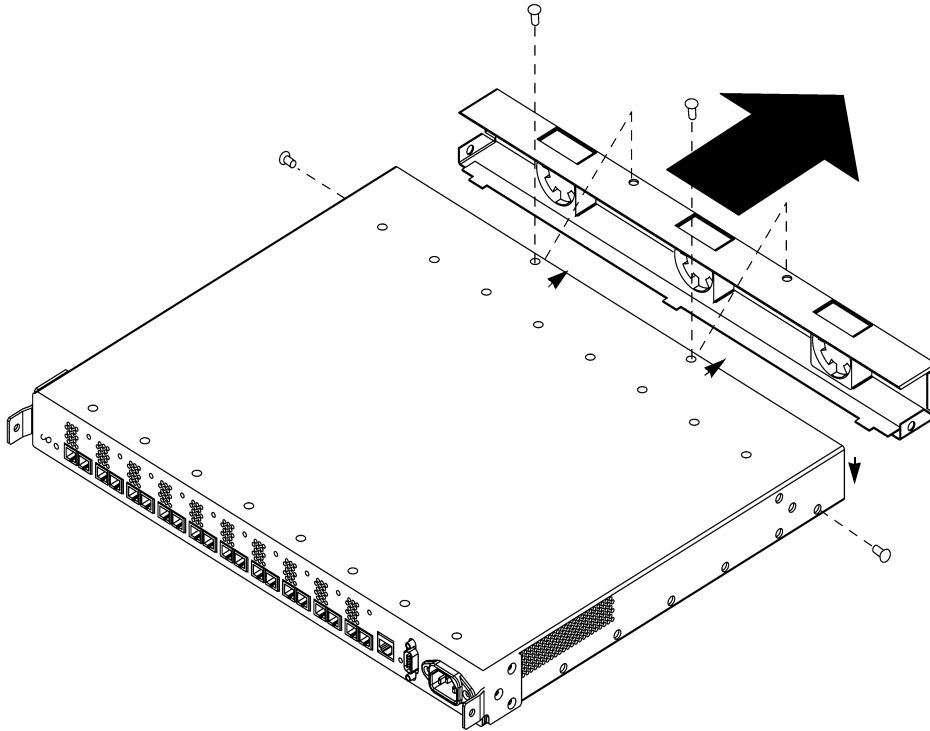

4. Remove the fan module.
5. To insert the new fan module, line up the tabs on the bottom of the fan with the tab openings on the hub (see Figure 22 for positioning). Push the fan module into the hub.

Figure 22 Replacing the Fan Module

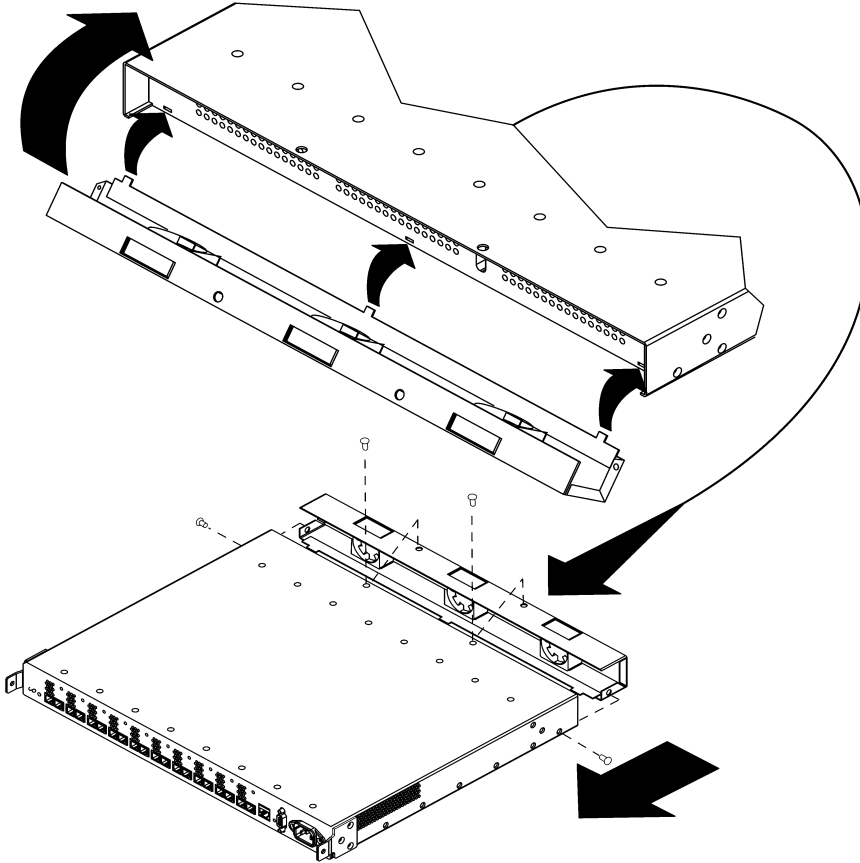

6. Fasten the four screws to secure the fan module.
7. Plug the power cord into the hub.

The hub powers on and runs the self-test. When the self-test is complete, the Power LED should remain lit and the Fault LED should be off.

Standard Configurations

Configuration Options

Replacement Parts

Operating Requirements

Environmental Specifications

Physical Characteristics

Reference Documents

Regulatory Statements

Laser Safety

Standard Configurations

Model S10 short-wave and model L10 long-wave hubs are available in standalone and factory-racked configurations (Figure 23 and Figure 24).

The short-wave or long-wave standalone models can be ordered with a customer-installable rackmount option for adding the hub to an existing cabinet.

Table 3 HP SureStore E Hub Product Numbers

Product Number	Description
HPA3724A	Standalone short-wave hub
HP A3724AZ	Factory-racked short-wave hub
HP A4839A	Standalone long-wave hub
HP A4839AZ	Factory-racked long-wave hub

Figure 23 HP SureStore E Hub, Standalone

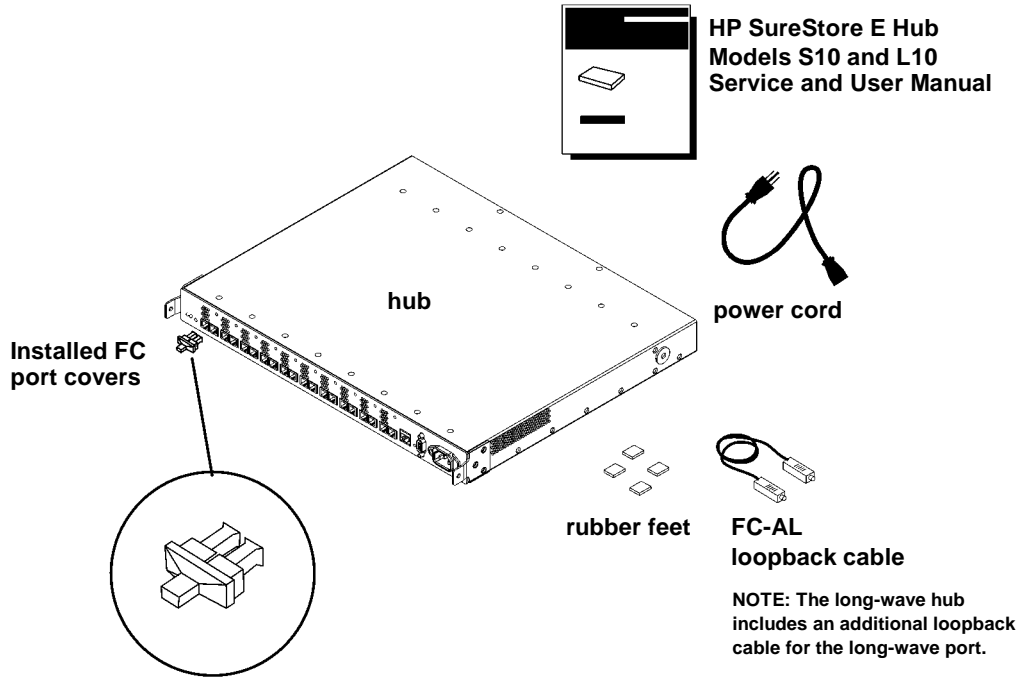
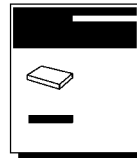
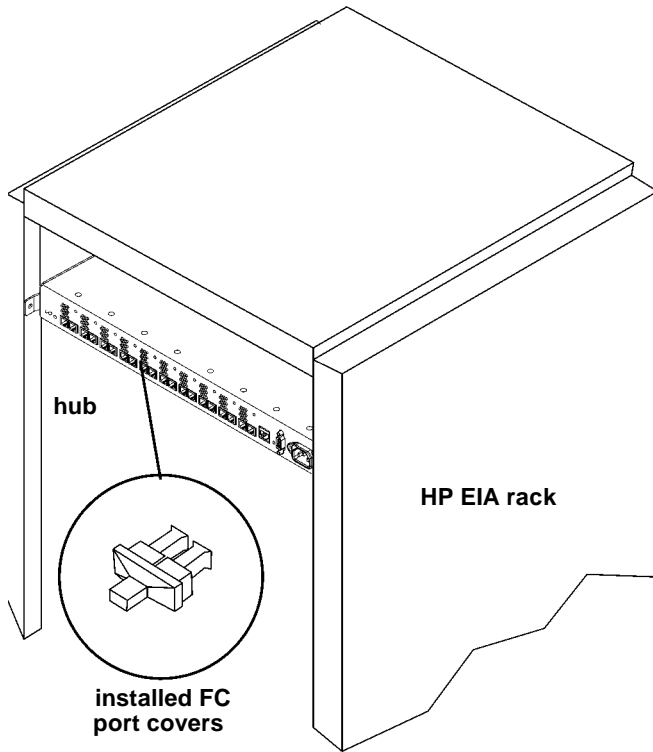
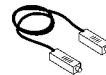

Figure 24 HP SureStore E Hub, Factory-Racked



**HP SureStore E Hub
Models S10 and L10
Service and User Manual**



FC-AL loopback cable

NOTE: The model L10 long-wave hub includes an additional loopback cable for the long-wave port.

Configuration Options

Model S10 short-wave and model L10 long-wave hubs can be ordered with the following options:

- A customer-installable rackmount kit for adding the hub to an existing cabinet (Table 4 and Figure 25)
- Cables of various lengths

Table 4 HP SureStoreE Hub Configuration Options

Option	Description
001	Includes one rackmount kit
AFY	Includes 16-m Fibre Channel cable
0Z5	Includes 50-m Fibre Channel cable
0Z6	Includes 100-m Fibre Channel cable

Fibre Channel Manager is the hub's software management tool. This tool allows you to remotely manage and monitor the health of the hub. Visit the Hewlett-Packard Software Depot (<http://www.software.hp.com>) for more information or to download Fibre Channel Manager at no charge.

Figure 25 Model S10 or L10 Option 001 Hub Rackmount Kit

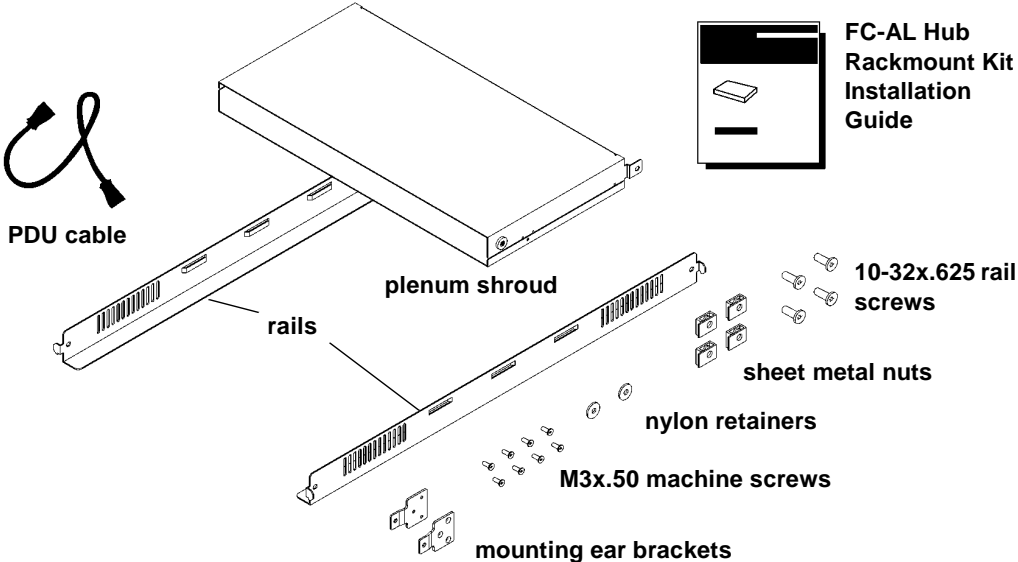

Replacement Parts

External parts on the hub are replaceable. The following figure and tables provide order numbers for replaceable parts. An HP sales representative can help you obtain the part you need.

Figure 26 HP SureStore E Hub Replaceable Parts

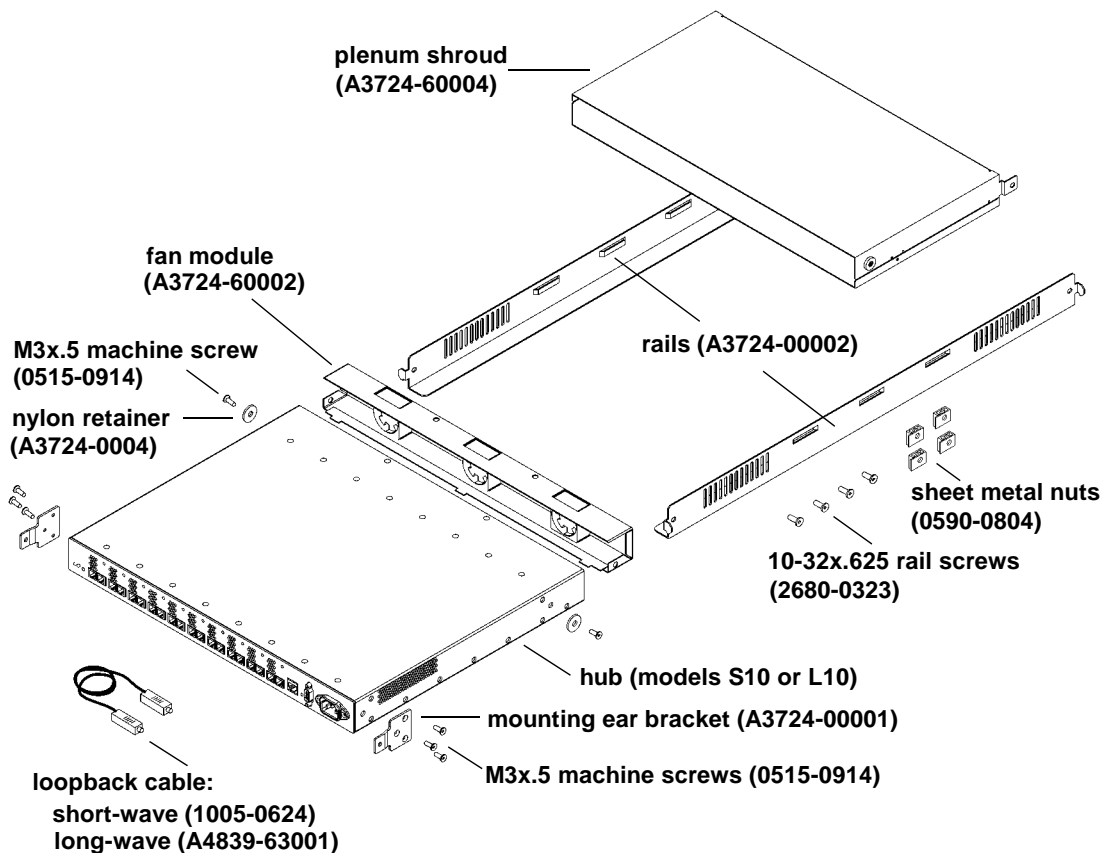

Table 5 HP SureStore E Hub Replaceable Parts and Service Part Numbers

Replaceable Part	Service Part Number
Mounting ear brackets	A3724-00001
Rails	A3724-00002
Nylon retainers	A3724-00004
Fan module	A3724-60002
Plenum shroud	A3724-60004
Rackmount kit	A3724-62001
Exchange short-wave hub	A3724-69001
Exchange long-wave hub	A4839-69001
FC-AL long-wave loopback cable	A4839-63001
FC-AL short-wave loopback cable	1005-0624
M3 x .50 machine screws	0515-0914
Sheet metal nuts	0590-0804
10-32 x .625 machine screws	2680-0323

Table 6 Multimode Fiber Optic Cable Part Numbers

Cable Description*	Customer Order Number	Service Part Number
16 m, 50 micron, multimode fiber optic	A3531A	1005-0586
50 m, 50 micron, multimode fiber optic	A3735A	1005-0365
100 m, 50 micron, multimode fiber optic	A3736A	1005-0366

* Hewlett-Packard has tested the AMP single-mode #504655-1 SC Connector and Fujikura Fibre Channel connector with lower metal content (as opposed to the connector with standard metal content) for compliance to FCC Article 15 for RFI in Class A environments. For other multi-mode lengths and specifications for single-mode cables, see Cable Plant Specifications on page 101.

Table 7 Power Cord Part Numbers

Description	Service Part Number
Argentina	8120-6869
Australia	8120-1369
Chile	8120-6980
Denmark	8120-2956
Europe	8120-1689
Israel	8120-8325
Japan	8120-4753
South Africa and India	8120-4211
Switzerland	8120-2104
United Kingdom	8120-1351
USA 120V	8120-1751
USA 240V	8120-3996

Operating Requirements

Software and Operating System Requirements

The hub does not require drivers or specific versions of operating systems. However, systems and FC-AL devices that can connect to the hub do have driver and operating system requirements. Contact an HP sales representative for information on hardware and software requirements for the FC-AL devices you plan to connect to the hub.

Physical and Cabling Requirements

Note	For short-wave ports, SC Connectors must be AMP multimode #504657-1 or equivalent to meet FCC Part 15 standards. For long-wave ports, SC Connectors must be AMP single-mode #504655-1 or equivalent to meet FCC Part 15 standards. Cable Plant Specifications on page 101 lists more requirements.
------	--

Model S10 Short-Wave Hub

The short-wave hub supports 10 non-OFC, short-wave FC-AL connections. In arbitrated loop topology, data rates and wavelength between ports must be the same. The short-wave hub supports only gigabit short-wave to gigabit short-wave connections using fiber cables.

For the short-wave hub, Hewlett-Packard recommends 50-micron multimode fiber cable for new installations but also supports 62.5-micron multimode fiber cable with SC-style connectors in existing installations. Installations can mix 50-micron and 62.5-micron cables.

Model L10 Long-Wave Hub

The long-wave hub supports short-wave gigabit to short-wave gigabit connections from ports 1 through 9 using fiber cables. The long-wave hub also supports a long-wave hub to long-wave hub connection from the long-wave port.

- For the long-wave port, Hewlett-Packard recommends 9-micron single-mode fiber cable.
- For ports 1 through 9, Hewlett-Packard recommends 50-micron multimode fiber cable for new installations but also supports 62.5-micron multimode fiber cable with SC-style connectors in existing installations.

Cable Plant Specifications

The cable plant includes losses of the fiber and splices and connectors (excluding those at the ends of the link that are accounted for in the transmitter and receiver specifications).

Table 8 Cable Plant Specifications: Single-Mode (2 km–10 km, 100 MB/sec)

Specification	Units	Value
Fiber type		Single-mode; step index
Fiber core	micron	9 (nominal)
Fiber Bandwidth (1 km)	MHz	Not applicable
Fiber Dispersion	Ps/nm	< 35
Return loss of cable plant with receiver connected	dB	> 12
Return loss of each individual connector or splice	dB	> 26
Cable plant loss	dB	< 6*

* HP suggests that the loss of a new single-mode cable plant be limited to 6dB or lower in order to maximize the probability that the cable plant will permit 10- km operation with the majority of long-wave hubs (HP-UX servers only). Larger losses are permissible if the receiver power is greater than -17dBm. For new installations, HP recommends that the single-mode fiber be low-loss fiber equivalent to Corning's premium grade of their single-mode SMF-28 cable with loss of 0.35 dB/km or lower in order to more easily attain the required signal power at the receiver in spite of losses due to connectors and splices.

Table 9 Cable Plant Specifications: 50-Micron Multimode (500 m, 100 MB/sec)
Non-OFC Operation

Specification	Units	Value
Fiber type		Multimode; graded index
Fiber core	micron	50 (nominal)
Fiber Bandwidth (1 km)	MHz	> 500 @ 850nm
Fiber Dispersion	Ps/nm	Not applicable
Return loss of cable plant with receiver connected	dB	> 12
Return loss of each individual connector or splice	dB	> 26
Cable plant loss	dB	< 6

Table 10 Cable Plant Specifications: 62.5-Micron Multimode (175 m, 100 MB/sec)
Non-OFC Operation

Specification	Units	Value
Fiber type		Multimode; graded index
Fiber core	micron	62.5 (nominal)
Fiber Bandwidth (1 km)	MHz	> 160 @ 850nm
Fiber Dispersion	Ps/nm	Not applicable
Return loss of cable plant with receiver connected	dB	> 12
Return loss of each individual connector or splice	dB	> 26
Cable plant loss	dB	< 6

Supported Hardware

Model S10 Short-Wave Hub

- Multimode 62.5-micron (175-meter) or 50-micron (500-meter) fiber cables
- HP-UX servers and HP NetServers and other FC-AL devices equipped with a compatible 1063-Mbps, short-wave, non-OFC adapter. Contact an HP sales representative for details on specific devices and required versions of operating systems.
- RS-232 configuration and diagnostics
- 10Base-T port for ethernet connection to HP-UX server for hub management tool (Fibre Channel Manager). The server must be running HP-UX 10.20 or 11.0.

Model L10 Long-Wave Hub

- **Ports 1-9:** Multimode 62.5-micron (175-meter) or 50-micron (500-meter) fiber cables. HP-UX servers and HP NetServers and other FC-AL devices equipped with a compatible 1063-Mbps, short-wave, non-OFC adapter. Contact an HP sales representative for details on specific devices and required versions of operating systems.
- **Long-Wave Port:** Single-mode 9-micron (3-km) fiber cables. HP long-wave, hub (model L10) equipped with a compatible long-wave port.
- RS-232 configuration and diagnostics
- 10Base-T port for ethernet connection to HP-UX server for hub management tool (Fibre Channel Manager). The server must be running HP-UX 10.20 or 11.0.

Supported Distances

Table 11 summarizes the supported distances between a host and devices connected to short-wave ports with 50-micron and 62.5-micron cables and long-wave ports with 9-micron cables. The table does not include combinations of mixed cable lengths.

Table 11 Supported Cable Distances

Connection	Short-Wave ¹ 50 micron (multimode)	Short-Wave ¹ 62.5 micron (multimode)	Long-Wave ² 9 micron (single-mode)
Host to Hub	500 m	175 m	Not supported
Hub to Hub	500 m	175 m	3 km ³
Hub to Device	500 m	175 m	Not supported
Total	1500 m	525 m	Varies

¹ Ports 1-10 on short-wave hub; ports 1-9 on long-wave hub

² Long-wave port on long-wave hub

³ Under certain conditions, single-mode 9-micron cables are supported at distances up to 10 km (see page 105 for more information). The 10-km capability is supported only for long-wave hubs connected to HP-UX servers.

Model S10 Short-Wave Hub

Note Stated distances assume 50-micron multimode cable.

The short-wave hub supports distances up to 500 meters between a server host and the hub, between a hub port and a connected FC-AL device, and between two short-wave hubs. The maximum distance between a host server and FC-AL devices connected to cascaded short-wave hubs is 1500 meters.

Model L10 Long-Wave Hub

Note	Stated distances assume 9-micron single-mode cable for the long-wave port and 50-micron multimode cable for the short-wave ports.
------	---

For ports 1 through 9, the long-wave hub supports distances of 500 meters between the port and a connected FC-AL device. For the long-wave port, the long-wave hub supports distances up to 3 kilometers between two long-wave hubs. Under certain conditions, cascaded long-wave hubs are supported at distances up to 10 kilometers. *The 10-km capability is supported only for long-wave hubs connected to HP-UX servers.*

To verify 10-km capability for the long-wave hub over an existing cable plant:

The received average optical power of the long-wave port on both long-wave hubs must be higher (more positive) than -17 dBm in order for the long-wave hubs to support cascade distances of up to 10 km. Use an optical power meter that measures average optical power at a wavelength of 1300 nm in dBm units (for example, the Fotec Model 712A Power Meter with Model A262 SC connector adapter).

To verify the long-wave port's received average optical power, do the following:

1. Power on both long-wave hubs and connect the long-wave ports with the 10-km single-mode cable.
2. Turn the optical power meter on. The meter performs a self-test.
3. If necessary, set the meter's wavelength to 1300 nm and measuring units to dBm.
4. Disconnect the Fibre Channel cable from the long-wave port of one of the two hubs.
5. Determine which connector of the Fibre Channel cable is the transmitter. Connect one plug of the Fibre Channel cable into the SC receptacle of the meter. If the meter does not indicate a signal, connect the other plug of the Fibre Channel cable.
6. Verify that the reading on the meter is higher (more positive) than -17 dBm *and* lower than -3 dBm.
7. Reconnect the Fibre Channel cable to the long-wave port.
8. Repeat steps 4 through 7 with the long-wave port of the second long-wave hub.

If both ends of the Fibre Channel cable are between the limits listed in step 5, the two long-wave hub's are verified for cascading up to 10 km using this cable plant. If the meter readings are not within range, verify that the Fibre Channel cable is securely connected to the hub's long-wave port. Also verify, that the cable connectors are clean by wiping them with a lint-free cloth dampened with reagent grade isopropyl alcohol and blowing the connectors dry with clean, compressed air.

Environmental Specifications

Table 12 Environmental Specifications for Model S10 Short-Wave and Model L10 Long-Wave Hubs

Environment	Limitations
Temperature:	
– operating	+5 to +40° C
– nonoperating	-40 to +70° C
Humidity:	
– operating	20 to 80% maximum relative humidity
– nonoperating	5 to 90% relative humidity at 65° C
Altitude:	
– operating	0 to 10,000 ft. at operating temperature
– nonoperating	10,000 to 15,000 ft. at nonoperating temperature
Power Line voltage range $\pm 10\%$ and frequency	100 VAC autoranging, 1.2 Amps, 50 to 60 Hz 240 VAC autoranging, .6 Amps, 50 to 60 Hz
Heat Dissipation	650 BTU/hr 165 kcal/hr

Physical Characteristics of Standalone Hub

Table 13 Physical Characteristics of Model S10 Short-Wave and Model L10 Long-Wave Hubs

Physical Dimensions	Product Alone	Packaged Product	
		with 16-meter cable	with 50/100-meter cable
Height	1.7 in. (43 mm)	13.0 in. (330 mm)	22.0 in. (559 mm)
Width	17.3 in. (439 mm)	27.5 in. (699 mm)	30.5 in. (775 mm)
Depth	14.0 in. (356 mm)	22.5 in. (572 mm)	21.0 in. (533 mm)
Weight	8 lbs.	30 lbs.	32/34 lbs.

Reference Documents

Installation Documents

- *Hewlett-Packard SureStoreE Hub Models S10 and L10 Service and User Manual* (A3724-90006)
- *Hewlett-Packard Fibre Channel Mass Storage Adapter Service and User Manual* (A3636-90002)
- *Configuring HP-UX for Peripherals (HP9000)* (B2355-90053)

Administration/Troubleshooting Documents

- *Hewlett-Packard Fibre Channel Manager User Manual*
- *HP-UX System Administration Tasks Manual* (B2355-90079)
- *Support Tools Manager User's Manual HP 9000 Series 700 and Series 800 PA-RISC Computer Systems* (5961-1612)

Fibre Channel Technology Documents

- *Fibre Channel: Connection-to-the-Future* (ISBN 1-878707-19-1)
- *The Fibre Channel Consultant: Arbitrated Loop* (ISBN 0-931836-82-4)
- *What is Fibre Channel?* (ISBN 0-9637439-1-0)

Regulatory Statements

A. FCC Statement (For U.S.A. Only)

The Federal Communications Commission (in 47 CFR 15.105) has specified that the following notice be brought to the attention of the users of this product.

This equipment has been tested and found to comply with the limits for a Class A digital device, pursuant to Part 15 of the FCC Rules. These limits are designed to provide reasonable protection against harmful interference when the equipment is operated in a commercial environment. This equipment generates, uses, and can radiate radio frequency energy and, if not installed and used in accordance with the instruction manual, may cause harmful interference to radio communications. Operation of this equipment in a residential area is likely to cause harmful interference in which case the user will be required to correct the interference at his own expense. The end user of this product should be aware that any changes or modifications made to this equipment without the approval of Hewlett-Packard could result in the product not meeting the Class A limits, in which case the FCC could void the user's authority to operate the equipment.

B. IEC Statement (Worldwide)

This is a Class A product. In a domestic environment this product may cause radio interference in which case the user may be required to take adequate measures.

C. Spécification ATI Classe A (France)

DECLARATION D'INSTALLATION ET DE MISE EN EXPLOITATION d'un matériel de traitement de l'information (ATI), classé A en fonction des niveaux de perturbations radioélectriques émis, définis dans la norme européenne EN 55022 concernant la Compatibilité Electromagnétique.

Cher Client,

Conformément à la Réglementation Française en vigueur l'installation ou le transfert

d'installation, et l'exploitation de cet appareil de classe A, doivent faire l'objet d'une déclaration (en deux exemplaires) simultanément auprès des services suivants:

- Comité de Coordination des Télécommunications 20, avenue de Ségur - 75700 PARIS
- Préfecture du département du lieu d'exploitation

Le formulaire à utiliser est disponible auprès des préfetures.

La déclaration doit être faite dans les 30 jours suivant la mise en exploitation.

Le non respect de cette obligation peut être sanctionné par les peines prévues au code des Postes et Télécommunications et celles indiquées dans la loi du 31 mai 1993 susvisée.

Arrêté du 27 Mars 1993, publié au J.O. du 28 Mars - ATI

D. Product Noise Declaration (Germany)

Acoustic Noise Emissions

LpA: 45 dB

At bystander position per ISO 7779.

All data are the results from type tests of the product configuration having the highest acoustic emissions.

Geräuschemission

LpA: 45 dB

Am fiktiven Arbeitsplatz nach DIN 45635 T. 19.

Die Daten sind die Ergebnisse von Typprüfungen an Gerätekonfigurationen mit den höchsten Geräuschemissionen:

E. VCCI Statement (Japan)

注意

この装置は、情報処理装置等電波障害自主規制協議会（VCCI）の基準に基づく第一種情報技術装置です。この装置を家庭環境で使用すると電波妨害を引き起こすことがあります。この場合には使用者が適切な対策を講ずるよう要求されることがあります。

Laser Safety

A. Certification and Classification Information

This product contains a laser internal to the Optical Link Module (OLM) for connection to the Fibre communications port.

In the USA, all models of the OLM are certified as Class 1 laser product and conform to the requirements contained in the Department of Health and Human Services (DHHS) regulation 21 CFR Subchapter J. The certification is indicated by a label located on the plastic OLM housing.

Outside the USA, all models of the OLM are certified as Class 1 laser components that conform to the requirements contained in the International Electrotechnical Commission (IEC) standard 825 (1994) and Amendment 1 (1990) along with the CENELEC (European Committee for Electrotechnical Standardization) European Normalization Standard EN 60825 (1992).

Certifications include one or more of the following: Recognized Component and Certified for Canada by Underwriters Laboratories, Certified by TUV (Germany).

The following figure shows the Class 1 information label specified in IEC 825 and CENELEC HD 482 51.

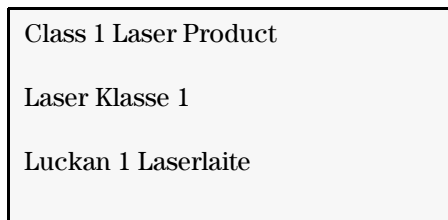

B. Product Information

Each communications port consists of a transmitter and receiver optical subassembly. The transmitter subassembly contains internally a semiconductor laser diode in the wavelength range of 780 to 1300 nanometers. In the event of a break anywhere in the fibre path, the OLM control system prevents laser emissions from exceeding Class 1 levels.

Class 1 laser products are not considered hazardous.

WARNING **There are no user maintenance or service operations or adjustments to be performed on any OLM model.**

C. Usage Restrictions

Failure to comply with these usage restrictions may result in incorrect operation of the system and points of access may emit laser radiation above the Class 1 limits established by the IEC and U.S. DHHS.

D. Laser Safety (Finland) LASERTURVALLISUUS

LASERTURVALLISUUS

LUOKAN 1 LASERLAITE

KLASS 1 LASER APPARAT

Fibre Channel 1063 MBaud Optical Link -kortille on asennettu optista tiedonsiirtoa varten laserlähetin, joka lähettää signaalit siihen kytketyn optisen kuidun kautta.

Normaalissa toimintatilassa lähetin on käyttäjälle turvallinen luokan 1 laserlaite, eikä käyttäjä voi altistua sen lähettämälle säteilylle. Optisen lähetinmoduulin turvallisuusluokka on määritetty standardin EN 60825 (1991) mukaisesti.

Optisessa lähetinmoduulissa ei ole huollettavia kohteita eikä sen tehtaalla tehtyjä säätöjä tule muuttaa. Lähetinmoduuli on myös suunniteltu siten, että turvallisuusluokan 1 säteilyrajat eivät ylity, vaikka lähetinmoduuliin kytketty optinen kuitu rikkoutuu tai kytketään irti lähettimen toimiessa.

Lähetinmoduulin turvallisen toiminnan varmistamiseksi on noudatettava tarkoin sen asentamisesta ja toiseen vastaanottavaan laitteistoon kytkemisestä annettuja ohjeita.

Tiedot optisessa lähetinmoduulissa käytettävien laserdiodien säteilyominaisuuksista:

Aallonpituus

(SW) 780 - 850 nm

(LW) 1300 nm

Declaration of Conformity

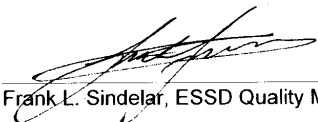
DECLARATION OF CONFORMITY according to ISO/IEC Guide 22 and EN 45014	
Manufacturer's Name:	Hewlett-Packard Company Enterprise Storage Business Unit
Manufacturer's Address:	8000 Foothills Blvd. Roseville, CA 95747 USA
declares, that the product	
Product Name:	Fibre Channel Arbitrated Loop Hub
Model Number(s):	A3724A/AZ, A4839A/AZ
Product Options:	All
conforms to the following Product Specifications:	
Safety:	IEC 950:1991 + A1, A2, A3, A4 / EN 60950:1992 + A1, A2, A3, A4 GB 4943-1995 IEC 825-1:1993 / EN 60825-1:1993, Class 1
EMC:	CISPR 22:1993 +A1, A2 / EN 55022:1994 +A1, A2 - Class A ¹ GB 9254-1988 EN 50082-1:1992 IEC 801-2:1991 / prEN 55024-2:1992, 4 kV CD, 8 kV AD IEC 801-3:1984 / prEN 55024-3:1991, 3 V/m IEC 801-4:1988 / prEN 55024-4:1993, 0.5 kV Signal Lines 1 kV Power Lines
Supplementary Information:	
The product herewith complies with the requirements of the Low Voltage Directive 73/23/EEC and the EMC Directive 89/336/EEC and carries the CE marking accordingly.	
1) The Product was tested in a typical configuration with a Hewlett-Packard 9000 Series 800 computer system, including mass storage.	
Roseville, March 9, 1999	 Frank L. Sindelar, ESSD Quality Mgr.
European Contact: Your local Hewlett-Packard Sales and Service Office or Hewlett-Packard GmbH, Department HQ-TRE, Herrenberger Straße 130, D-71034 Böblingen (FAX: + 49-7031-14-3143)	

GLOSSARY

Arbitrated Loop

See *Fibre Channel - Arbitrated Loop*.

Child Hub

The HP SureStore E short-wave and long-wave hubs support a cascaded topology. In a cascaded hub topology, the child hub is the hub that is *not* connected to the LAN (ethernet). HP SureStore E hubs are configured as a parent or child hub through their RS-232 interface.

Device

See *FC-AL Device*.

Enclosure

The box, rack, or set of boxes containing one or more devices. It may provide the powering, cooling, mechanical support, and external electronic interfaces for those devices.

FC-AL Device

A device that uses Fibre Channel Arbitrated Loop, which consists of one or more NL_Ports.

FC-AL Port

The port on the hub that provides connection between the FC-AL adapter and the FC-AL link.

Fiber

The fiber optic cable made from thin strands of glass through which data in the form of light pulses is transmitted (LASER, LED). It is used for high-speed transmission over medium to long distances.

Fibre Channel

Logically, Fibre Channel is a bidirectional, full-duplex, point-to-point, serial data channel structured for high performance capability. Physically, the Fibre Channel is an interconnection of multiple communication ports, called NL_Ports, interconnected by a switching network, called a fabric, a point-to-point link or an arbitrated loop. Fibre Channel is a generalized transport mechanism that has no protocol of its own or native input/output command set, but can transport any existing Upper Level Protocols (ULPs) such as SCSI and IPI at speeds of 100 Mbytes/sec over distances of up to 10 kilometers over optical links. Fibre Channel can interconnect two devices in a point-to-point topology, from two to 126 devices in an arbitrated loop, and up to 224 devices in a fabric switched topology.

Fibre Channel Arbitrated Loop (FC-AL)

One of three existing Fibre Channel topologies in which two to 126 devices are interconnected serially in a single loop circuit without hubs and switches. Communication is managed using an arbitration process in which the lowest port address has the highest priority for communicating. The arbitrated loop topology supports all classes of service and guarantees in-order delivery of frames when the source and destination are on the same loop.

Link

For Fibre Channel, a connection between two nodes, each having at least one N_Port, interconnected by a pair of optical or copper links, one inbound and one outbound.

Long Wave

Lasers or LEDs that emit light with wave lengths around 1300 nm. Long-wave lasers are used for long Fibre Channel links, from 700 to 2000 meters. They are typically used with single-mode fiber of a 9-micron core size.

Loop Address

The unique ID of a node in Fibre Channel loop topology, sometimes referred to as a loop ID.

N_Port

A “Node” port. A Fiber Channel-defined hardware entity that performs data communication over the FC-AL link. It is identifiable by a unique World Wide Name. It can act as an originator or a responder.

N_Port Identifier

A unique address identifier by which an N_Port is uniquely known. It consists of a Domain (most significant byte), an Area, and a Port, each 1-byte long. The N_Port identifier is used in the Source Identifier (S_ID) and Destination Identifier (D_ID) fields of an FC-AL frame.

Parent Hub

The HP SureStore E short-wave and long-wave hubs support a cascaded topology. In a cascaded hub topology, the parent hub is the hub that *is* connected to the LAN (ethernet). HP SureStore E hubs are configured as a parent or child hub through their RS-232 interface.

Short Wave

Lasers or LEDs that emit light with wave lengths around 780 nm or 850 nm. Short-wave lasers are used for FC-AL links up to approximately 700 meters. They are typically used with multimode fiber. The preferred fiber core size is 50 micron because this fiber has large bandwidth so that the distance is limited by the fiber attenuation. A 62.5-micron core size is also supported for compatibility with existing FDDI installations. Fiber of this type has smaller bandwidth and, in this case, the distance is limited by the fiber bandwidth.

Topology

The physical or logical layout of nodes on a network. FC-AL topologies include point-to-point, FC-AL, and fabric. The hub supports FC-AL topology.



Numerics

- 0200
 - self-test value 64
- 10Base-T LED
 - normal state 71
- 10Base-T port
 - long-wave hub 15
 - short-wave hub 14

A

- address
 - See also* IP addresses
 - MAC 27, 65
 - reviewing for duplicates 32
 - troubleshooting 68, 75
- address map. *See* device map
- altitude 107

B

- bend radius of fiber cable 87
- Boot menu
 - displaying 50
- bypass control 13
- bypass persistence setting 56

C

- cables
 - See also* serial cable
 - bend radius 87
 - connectors 100
 - maximum supported distances 104
 - options 95, 98
 - recommended 100
 - requirements 100
 - supported for long-wave hub 103

- supported for short-wave hub 103
 - treatment of 38, 87
 - troubleshooting 76
- cabling
 - example of nonsupported 37
 - examples of correct 32, 33
 - examples of incorrect 35
 - troubleshooting 68
- cabling map 38
 - See also* device map
- cascaded hubs 13
 - configuring 60
- cascaded long-wave hubs
 - configuring 60
 - example of correct cabling 34
 - example of nonsupported 37
 - examples of incorrect cabling 36
 - firmware requirements 20
 - supported topology 19
- cascaded short-wave hubs
 - configuring 60
 - example of correct cabling 33
 - example of nonsupported 37
 - examples of incorrect cabling 36
 - firmware requirements 18
 - supported topology 18
- Cautions
 - bending fiber cables 38
 - cascaded long-wave hubs 19
 - cleaning connectors 87
 - device agent code update 53, 82
 - firmware update sequence 50, 52
 - incorrect device connections 32
 - power failure during firmware update 49
 - saving changes 58

- trap IP address deletion 59
- chassis, opening
 - warning 64, 86
- child hub
 - See also* hub
 - configuring 60
 - definition 60, 117
- configuration
 - loop cabling 32
- configurations
 - options 95
 - standard 92
- connections, port
 - completing installation of 38
 - verifying 40
- connections, RS-232
 - terminal emulator settings 46
 - terminal settings 47
- connectors
 - caution 87
 - cleaning 87
 - troubleshooting 76
- controller
 - updating firmware 50, 82

- D**
- data rate requirements 100
- default values
 - resetting 59
 - SNMP names 59
- depth 108
- device agent code
 - caution 50, 52
 - updating 52, 81
- device map
 - troubleshooting 77
- devices
 - addressing 32, 38
 - connecting to the hub 38
 - hardware/software requirements 100
 - preparing for installation 32
 - supported wave type 100

- troubleshooting 68, 75
- verifying connection 40

- diagnostic tests
 - running 64

- distances
 - increasing 13
 - maximum supported 104
 - maximum supported for cascaded long-wave hubs 19
 - maximum supported for cascaded short-wave hubs 18
 - maximum supported for single short-wave hub 17

- drivers
 - requirements 100
 - troubleshooting 75
- dumb terminal. *See* terminal
- dynamic recognition of nodes 13

E

- EIA height 27
- exchange part number
 - long-wave hub 98
 - short-wave hub 98

F

- failed nodes 13
- fan module
 - description 16
 - part number 98
 - removing 89
 - replacing 88
- fans
 - troubleshooting 73, 74
- fault LED
 - diagnostics for 64
 - during self-test 25, 31
 - long-wave hub 15
 - short-wave hub 14
 - troubleshooting 68, 70, 73, 74, 75
- features 13
 - physical characteristics 108

fiber cables
 bend radius 87
 recommended for long-wave hub 103
 recommended for short-wave hub 103
 treatment of 38, 87
 troubleshooting 76

Fibre Channel connector
 caution 87
 cleaning 87
 long-wave hub 15
 short-wave hub 14

Fibre Channel Manager
 configuring cascaded hubs 60
 enabling at hub 57–63
 firmware requirements 48
 firmware requirements for cascaded
 hubs 18, 20
 overview 12
 port bypass 76

Fibre Channel ports
 long-wave hub 15
 short-wave hub 14

firmware
 caution 50, 52
 device agent code 81
 hub controller 82
 incompatible 79
 obtaining 49
 recovery 80
 requirements for cascaded hubs 18, 20
 troubleshooting 79
 updating 48–56
 updating device agent code 52
 updating hub controller 50

front panel
 long-wave hub 15
 positioning in rack 27
 short-wave hub 14

G

gateway address
 setting 57

get community name
 default value 58

glass fractures 87

H

hardware
 requirements 100
 supported 103

heat dissipation 107

height 108

Hewlett-Packard software depot 49

HP A3724A (model S10 short-wave) 92

HP A3724AZ (model S10 short-wave) 92

HP A4839A (model L10 long-wave) 92

HP A4839AZ (model L10 long-wave) 92

hub
 See also long-wave hub
 See also short-wave hub
 connecting devices 38
 connecting to the server 38
 EIA height 27
 enabling management 57–63
 example of nonsupported cabling 37
 examples of correct cabling 32
 examples of incorrect cabling 35
 features 13
 identification information 65
 installation 21–40
 installing standalone model 24
 long-wave exchange part number 98
 maximum supported distances 104
 menus 43–65
 models 92
 mounting in rack 27
 options 95
 overview 12
 rear panel 16
 recommended cables 100
 resetting 14, 15
 short-wave exchange part number 98
 supported hardware 103
 unpacking 24

verifying operation 25

Hub Information menu

displaying 65

humidity 107

I

installation 21–40

connecting devices 38

overview 22

preparing devices 32

preparing for 23

rackmounting the hub 27

unpacking the hub 24

verifying connections 40

verifying hub operation 25

intermittent signals 87

internet address

Hewlett-Packard software depot 12, 49

ioscan

troubleshooting 68, 75

verifying connections 40

IP addresses

caution 59

setting for default gateway 57

setting for hub 57

setting for subnetting mask 57

setting for trap server 60

L

LEDs

10Base-T status 14, 15

fault 14, 15

long-wave hub 15

port 14, 15

power 14, 15

short-wave hub 14

troubleshooting 70

light signal 87

long-wave hub

See also hub

example of correct cabling 33

example of incorrect cabling 36

example of nonsupported cabling 37

exchange part number 98

features 13

maximum supported distances 105

models 92

product numbers 92

recommended cables 101

supported hardware 103

supported topology 19

loop

duplicate addresses 32, 38

loop configuration 32, 33

long-wave hub 34

loop ID 32, 38

troubleshooting 68, 75

loop map. *See* device map

loopback cable

long-wave part number 98

short-wave part number 98

troubleshooting 69, 76

M

MAC address

determining from front panel 27

determining from RS-232 interface 65

main menu

displaying 43

not displayed 79

options 43

maintenance 85–90

Management Options menu

displaying 60

management tool. *See* Fibre Channel Manager

Manufacturing Settings menu

displaying 54

map, device

troubleshooting 77

masks

subnet 57

master hub

enabling 54, 61, 62

media access control address. *See* MAC address

menus

- Boot 50
- Hub Information 65
- Management Options 60
- Manufacturing Settings 54
- Network Setup 58
- Proxy Master 54, 61, 62
- Set sysDescr String 54
- Set System OID 55
- tips for using 44
- troubleshooting 79

MIB-2 system name

- value 59

models 92

mounting ear brackets, part number 98

N

Network Setup menu

- displaying 58

nodes

- dynamic recognition of 13

nylon retainers, part number 98

O

OmniBook. *See* PC

operating system requirements 100

overview

- Fibre Channel Manager 12
- hub 12

P

parent hub

- See also* hub
- configuring 60
- definition 60, 119

part numbers 97

parts

- replacement 97

PC

- setting up a connection to 45

pinging the hub

- installation 26
- troubleshooting 78

plenum shroud

- installing in rackmount hub 29
- part number 98

plug-and-play capabilities 13

port covers 87

port LED

- troubleshooting 69, 70, 75, 77

ports

- bypass persistence setting 56
- bypassed by Fibre Channel Manager 76
- long-wave hub 15
- short-wave hub 14
- treatment of 87

power connector

- long-wave hub 15
- short-wave hub 14

power cord

- troubleshooting 72

power failure

- caution 49

power LED

- during self-test 25, 31
- long-wave hub 15
- short-wave hub 14
- troubleshooting 70, 72

power line 25, 107

product numbers 92

prompt

- not displayed 79

Proxy Master menu

- displaying 54, 61, 62

R

rackmount kit 92, 98

- assembly 27

rackmounting the hub 27

rail

- installing in rack 28
- part number 98

rail nuts, part number 98

rail screws, part number 98

rear panel 16

receive port, treatment of 87
reference documents 109
removing the fan module 89
replacement parts 97
replacing the fan module 88
 warning 88
requirements
 cable 100
 devices connected to the hub 100
 hardware 100
 software 100
 systems connected to the hub 100
Reset button
 long-wave hub 15
 short-wave hub 14
resetting the hub 14, 15
RS-232 port
 functions of 41–65
 long-wave hub 15
 setting up a connection 45
 short-wave hub 14
 troubleshooting 79

S

screws, part number 98
self-test
 fault LED 25, 31
 initializing 25
 power LED 25, 31
 running 64
 troubleshooting 70, 73
 values 64
serial cable
 for dumb terminal connection 46
 for PC connection 45
serial interface
 troubleshooting 79
serial number
 viewing 65
server
 connecting to the hub 38
set community name
 default value 59
Set sysDescr String menu
 displaying 54
Set System OID menu
 displaying 55
short-wave hub
 See also hub
 example of correct cabling 32
 example of nonsupported cabling 37
 examples of incorrect cabling 35
 exchange part number 98
 features 13
 maximum supported distances 104
 models 92
 product numbers 92
 recommended cables 100
 supported hardware 103
 supported topologies 17
signals, intermittent 87
SNMP trap community name
 default value 59
SNMP values
 resetting default values 59
 verifying and setting 58
software depot
 hub firmware 49
 internet address 12, 49
software requirements 100
specifications
 environmental 107
 physical 108
speed
 verifying compatibility 32
standalone hub
 installing 24
standard configurations 92
status messages
 loop 79
subnetting mask
 setting 57
supported hardware 103

T

- temperature 107
- terminal
 - setting up a connection to 46
- terminal emulator
 - software required 45
- topologies
 - long-wave hub 19
 - short-wave hub 17
 - supported 17
- topology 100
- transmit port, treatment of 87
- trap community name
 - default value 59
- trap server IP address
 - caution 59
 - setting 59
- troubleshooting 67–83
 - LED indicators 70
 - procedures 68

U

- URL
 - Hewlett-Packard software depot 12, 49

V

- voltage
 - operating 25
 - requirements 107
 - troubleshooting 72

W

- Warnings
 - chassis 64, 86
 - OLM model 114
 - replacing the fan module 88
 - uninsulated parts 64, 86
- wavelength
 - requirements 100
 - verifying compatibility 32
- weight 108
- width 108

Reader Comment Sheet

Hewlett-Packard SureStore E Hub Models S10 and L10 Service and User Manual

We welcome your evaluation of this manual. Your comments and suggestions will help us improve our publications. Remove this page and mail or FAX it to 916-785-2299. Use and attach additional pages if necessary.

	Agree				Disagree	N/A
The manual is well organized.	<input type="radio"/>	<input type="radio"/>	<input type="radio"/>	<input type="radio"/>	<input type="radio"/>	<input type="radio"/>
The information is technically accurate.	<input type="radio"/>	<input type="radio"/>	<input type="radio"/>	<input type="radio"/>	<input type="radio"/>	<input type="radio"/>
Information is easy to find.	<input type="radio"/>	<input type="radio"/>	<input type="radio"/>	<input type="radio"/>	<input type="radio"/>	<input type="radio"/>
Step-by-step procedures are easy to perform.	<input type="radio"/>	<input type="radio"/>	<input type="radio"/>	<input type="radio"/>	<input type="radio"/>	<input type="radio"/>
There are enough examples and pictures.	<input type="radio"/>	<input type="radio"/>	<input type="radio"/>	<input type="radio"/>	<input type="radio"/>	<input type="radio"/>
The examples and pictures are useful.	<input type="radio"/>	<input type="radio"/>	<input type="radio"/>	<input type="radio"/>	<input type="radio"/>	<input type="radio"/>

Comments _____

Name: _____	Phone: _____
Title: _____	fax: _____
Company: _____	E-mail: _____
Address: _____	ZIP: _____
City & State: _____	Country: _____

___ Check here if you would like a reply.

Hewlett-Packard has the right to use submitted suggestions without obligation, with all such ideas becoming the property of Hewlett-Packard.

ESSD Roseville Information Engineering

A3724-96009 E0899



NO POSTAGE
NECESSARY
IF MAILED
IN THE
UNITED STATES

BUSINESS REPLY MAIL
FIRST CLASS MAIL PERMIT NO. 256 ROSEVILLE, CA
POSTAGE WILL BE PAID BY ADDRESSEE

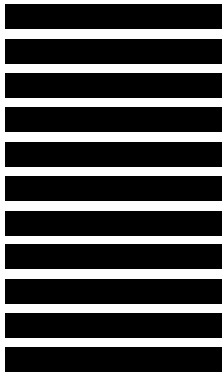

Attention: Information Engineering (MS5668)

Hewlett-Packard Company
Enterprise Storage Solutions Division
8000 Foothills Boulevard
Roseville, CA 95747-5668

Fold Here

Copyright © 1999
Hewlett-Packard Company
Printed in U.S.A.

Manual Part Number
A3724-90006

E0899

Manufacturing Part Number
A3724-96009

